

INSTRUCTIONS FOR INSTALLATION AND SERVICING

**Wall mounted
THERMOcompact®**
for central heating
**Fan-assisted
Room Sealed type**

This appliance shall be installed in accordance with the relevant Codes of Practice by British Gas or by an authorized installer (CORGI member).

These instructions should be left with the user when the installation is completed.

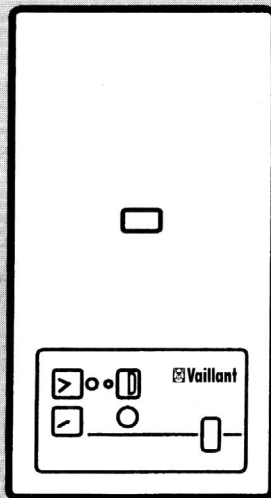

VC GB 112 EH
GC-No. 41 044 02

VC GB 142 EH
GC-No. 41 044 09

VC GB 112 EB
VC GB 142 EB
For use with L.P.G.



HEATING, CONTROLS, HOT WATER.

Contents

	Page		Page
1 Introduction	2	10 Electrical installation	23
2 Technical data	3	11 Commissioning and testing	31
3 Construction of appliance	4	12 Assembling	35
4 Function	5	13 Servicing of boiler	36
5 General requirements	6	14 Replacement of parts	40
6 Dimensions	14	15 Fault finding	53
7 Installation of the boiler	15	16 Electrical diagrams	59
8 Delivery	16	17 Short part list	61
9 Installation sequence	17	18 Technical data	64



The THERMOcompact system boiler carries the 'CE' Mark. This demonstrates that the boiler fulfils the essential requirements of the Gas Appliance Directive (Directive 90 / 396 / EEC) and The Gas Appliances (Safety) Regulations 1992.

1 Introduction

This Vaillant gas-fired boiler is a wall hung room sealed fan-assisted appliance for use with central heating and hot water storage cylinder systems.

Note to Installers

The boiler can be installed on an outside or inside wall inside the building.

The boiler is **not** suitable for external installation. The air/flue duct elbow can be set to allow the air/flue duct to connect to the boiler at any angle in the horizontal plane.

Additional bends and elbows may be installed in the air/flue duct. See separate flue instructions supplement.

Output ratings are shown in "Technical Data". The boiler is designed for use in a sealed water system with pumped circulation.

Contact the manufacturer for information on open vented installations.

Circulation pump, expansion vessel, automatic bypass, terminal box, control and safety devices are provided with the appliance.

This boiler does not have a pilot burner. The main burner is ignited electronically direct via two ignition electrodes and checked by means of a flame sensor.

The sealed system pressure relief valve is also provided.

An automatic system by-pass is included in the boiler.

If desired an inhibitor may be used in the system. Guidance on the use of inhibitors is contained in these instructions.

2 Technical Data

We cannot accept responsibility for damage as a result of non-observance of these installation and servicing instructions. Subject to alteration.

Type	VC GB 112 EH	VC GB 142 EH	Units
Nominal heating capacity	10.5 (35840) (37.8)	14.0 (47780) (50.4)	kW (BTU/h) (MJ/h)
Nominal heating input (based on gross C.V.)	13.0 (44370) (46.8)	17.8 (60750) (64.1)	kW (BTU/h) (MJ/h)
Main burner jet size for NG	6 x 7/140	8 x 7/140	number x mark.
Burner setting pressure max rate ignition rate	8.2 ± 0.8 (3.3 ± 0.3) 1.9 (0.8)	8.0 ± 0.8 (3.2 ± 0.3) 1.5 (0.6)	mbar (in WG) mbar (in WG)
Minimum water flow for heating system 20 °C rise	452 (99)	602 (132)	l/h (Imp. Gal./h)
Delivered gas Gross C.V. (s.t.) Gas consumption (s.t.)	G 20 37.8 (1014) 1.24 (0.73)	G 20 37.8 (1014) 1.70 (1.00)	MJ/m ³ (BTU/ft ³) m ³ /h (c.f.m.)
Water capacity of heat exchanger	0.41 (0.09)	0.41 (0.09)	l (Imp. Gal.)
Max. nominal flow temperature	90 (194)	90 (194)	°C (°F)
Maximum total water capacity of heating system (cold ¹⁾) for sealed system	90 (20)	90 (20)	l (Imp. Gal.)
Pump pressure available for central heating system	0.25 (8.4)	0.25 (8.4)	bar (feet)
Weight	40 (88)	40 (88)	kg (pound)
Electric connection Voltage Input internal Fuse / external Fuse	230-240/50 95 2 / 3	230-240/50 95 2 / 3	V~/Hz W Amp (slow)

¹⁾ For systems having a larger water capacity an additional expansion vessel can be installed easily.

3 Construction of appliance

- 1 Air/flue duct*
- 4 Combustion chamber
- 5 Viewing window
- 6 Gas control unit with operator
- 7 Pressure differential switch
- 9 Circulating pump
- 11 Pressure gauge
- 12 Flow thermometer
- 17 Terminal box electric system
- 18 Flow temperature selector
- 19 Fuses F 2 A
- 21 Lock-out reset switch
- 22 Lock-out red neon
- 24 Main switch
- 25 Fuse electronic system - 0.16 A
- 26 Air pressure switch
- 28 NTC flow sensor
- 29 CH overheat thermostat

* The connection elbow is supplied together with the accessory No. 9023 (air/flue duct).

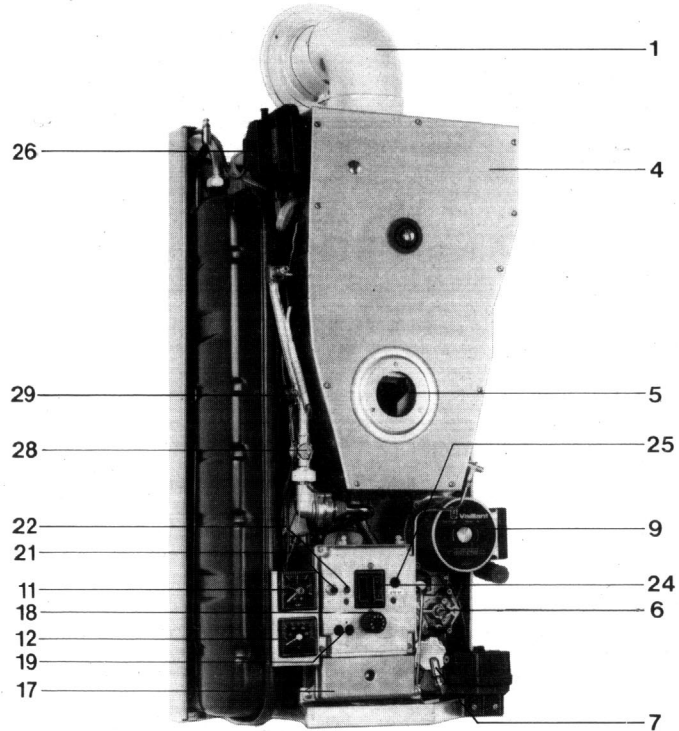

Fig. 1 (The picture shows the VCGB 112 EH)

4 Function

- 1 Flue gas duct
- 2 Air duct
- 3 Main heat exchanger
- 4 Venting point
- 5 Combustion chamber
- 6 Automatic air vent
- 7 Flame sensor electrode
- 8 Burner
- 9 Gas section
- 10 Gas operator
- 11 C.H. expansion vessel pressure test point
- 12 C.H. expansion vessel
- 13 Circulating pump
- 14 Gas service cock
- 15 C.H. pressure relief valve
- 16 C.H. return service cock
- 17 C.H. system
- 18 C.H. flow service cock
- 19 System bypass
- 20 Gas supply
- 21 Electronic control box
- 22 Fan
- 23 Ignition electrodes
- 24 N.T.C. flow sensor
- 25 Air pressure switch
- 26 Overheat cut-off sensor
- 27 Differential valve
- 28 C.H. overheat thermostat

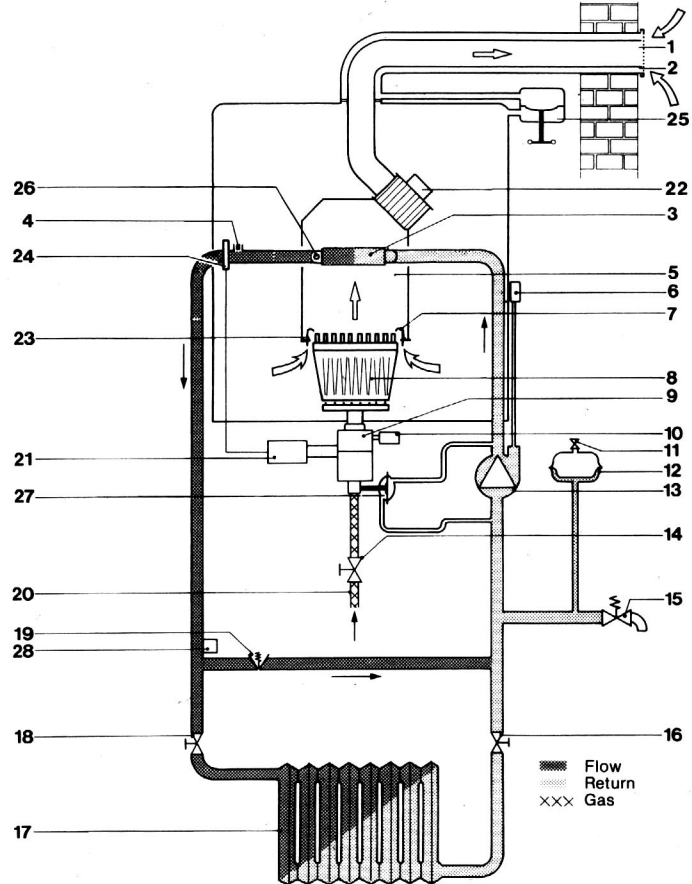

Fig. 2

5 General requirements

5.1 Related documents

The installation of the boiler must be in accordance with the relevant requirements of Gas Safety (Installations and Use) Regulation 1994*, current I.E.E. Wiring Regulations and the by-laws of the local Water-Undertaking. It should be in accordance with any relevant requirements of the Local Authority, Building Regulations, Building Standards (Scotland) Regulations and the relevant recommendations of the following British Standard Codes of Practice:

BS 5440: Flues and ventilation of gas fired boilers not exceeding 60 kW:

Part 1: Flues

Part 2: Ventilation.

BS 5449: Specification for forced circulation hot water for domestic premises.

BS 5546: Specification for gas hot water supplies for domestic premises.

BS 6700: Services supplying water for domestic use within buildings and their curtilages.

BS 6798: Specification for installation of gas fired boilers not exceeding 60 kW input.

BS 6891: Specification for installation of low pressure gas pipework up to 28 mm (R1) in domestic premises (2nd family gas).

BS 7593: Treatment of water in domestic hot water central heating systems.

BRITISH GAS PUBLICATION DM2:

Guide for Installation in Timber Framed Housing.

Unvented primary circuits may be filled or replenished by means of a temporary connection between the circuit and a supply pipe provided a double check valve or some other no less effective backflow prevention device is permanently connected at the inlet to the circuit and the temporary connection is removed after use.

*) Gas Safety (Installation and use) Regulation, 1994:

It is the law that all gas appliances are installed by competent persons, in accordance with the above regulations. Failure to install appliances correctly could lead to prosecution. It is in your own interest, and that of safety, to ensure that the law is complied with.

5.2 Location

The location chosen for the boiler must permit the provision of a satisfactory flue termination. The location must also provide adequate space for servicing and air circulation around the heater. The boiler may be installed in any room, although particular attention is drawn to the requirements of the I.E.E. Regulations and, in Scotland, the electrical provisions of the building regulations, in respect of the installation of the boiler in a room containing a bath or shower.

Note: Where a room sealed appliance is installed in a room containing a bath or shower, any electrical switch or appliance control utilising mains electricity should be so situated that it cannot be touched by a person using the bath or shower.

Where the installation of the boiler will be in an unusual location, special procedures may be necessary and BS 6798 gives detailed guidance on this aspect.

A compartment used to enclose the boiler must be designed and constructed specifically for this purpose. An existing cupboard or compartment may be used provided that it is modified for the purpose.

Details of essential features of cupboard/compartment design including airing cupboard installations are given in BS 6798.

5.3 Gas supply

The local gas supplier should be consulted at the installation planning stage in order to establish the availability of an adequate supply of gas.

An existing service pipe must not be used without prior consultation with the local gas supplier.

A gas meter is connected to the service pipe by the local gas supplier or their contractor. An existing meter should be checked to ensure that it is capable of passing an additional 1.24 m³/h (43.8 ft³/h) before the VC GB 112EH and 1.70 m³/h (60.0 ft³/h) before the VCGB 142 EH is installed.

Installation pipes should be fitted in accordance with BS 6891.

Pipework from the meter to the boiler must be of an adequate size. Do not use pipes of a smaller size than the boiler gas connection. The complete installation must be tested for soundness and purged as described in BS 6891.

5.4 Electrical supply

Wiring external to the boiler must be installed in accordance with the current I.E.E. Regulations and any local regulations which apply.

The boiler is supplied for connection to 230-240 V~, 50 Hz. Fuse rating is 3 A.

THIS APPLIANCE MUST BE EARTHED. The method of connection to the mains electricity supply must provide a means of completely isolating the boiler and its ancillary controls. Isolation is preferably by the use of a fused three-pin plug and unswitched shuttered socket outlet, both complying with the requirements of BS 1363. Alternatively, a 3 Amp fused double-pole switch with a 3 mm contact separation on both poles may be used.

5.6 Air supply

Detailed recommendations for air supply are given in BS 5440:2. The following notes are intended to give general guidance.

The fan-assisted balanced flue THERMO-compact does not require the room or internal space to have a permanent air vent.

air vent position \ appliance		VCGB 112EH
High level	Air from room or internal space	117 cm ² 17.9 in ²
	Air direct from outside	59 cm ² 8.9 in ²
Low level	Air from room or internal space	117 cm ² 17.9 in ²
	Air direct from outside	59 cm ² 8.9 in ²

5.6.1 Cupboard or compartment air supply

Where the boiler is to be installed in a cupboard or compartment, permanent air vents are required for cooling purposes at high and low level. These air vents must either communicate with the room or internal space or be direct to outside air.

The minimum effective areas of the permanent air vents required in the cupboard or compartment are specified below and are related to the maximum rated heat input of the unit.

air vent position \ appliance		VCGB 142EH
High level	Air from room or internal space	160 cm ² 24.3 in ²
	Air direct from outside	80.1 cm ² 12.1 in ²
Low level	Air from room or internal space	160 cm ² 24.3 in ²
	Air direct from outside	80.1 cm ² 12.1 in ²

Note: Both air vents must communicate with the same room or internal space or must be both on the same wall to the outside air.

5.7 Water circulating system

For general guidance reference should be made to the British Gas Publication — BRITISH GAS SPECIFICATIONS FOR DOMESTIC WET CENTRAL HEATING SYSTEMS.

Detailed recommendations for the water circulation system are given in BS 6798 and BS 5449:1 (for smallbore and microbore systems).

Detailed recommendations for the domestic hot water system are given in BS 5546 and BS 6700. The hot water storage cylinder must be of the double feed indirect type. Single feed indirect cylinders must not be used on sealed systems.

It is recommended that copper tubing to BS 2871:1 is used for all water carrying pipework. Any pipework not forming part of the useful heating surface should be insulated to help prevent heat loss and possible freezing, particularly where pipes are run through roof spaces and ventilated under-floor spaces.

Draining taps must be located in accessible positions which permit the flushing and draining of the complete heating and hot water systems. Draining taps should be at least ½" BSP nominal size and be in accordance with BS 2879.

Particularly where a new boiler is to be fitted to an existing system, it is good practice that the system is thoroughly cleansed. This cleansing should take place prior to the fitting of the new boiler and be in accordance with BS 7593.

For advice on the application of system cleansers contact Sentinel, Grace Dearborn Ltd., Widnes, Cheshire WA8 84D, Tel. 01514951861.

5.8 Radiator sizing

Typical sealed central heating and stored hot water installations are shown in figs. 4 and 5.

This Vaillant appliance is designed to operate on a temperature difference around the heating system of 20°C.

The mean radiator temperature for sizing purpose will therefore be the boiler flow temperature minus 10°C.

For example:

Boiler flow temp. = 86°C

(Boiler thermostat knob setting 8—9).

Mean radiator temp. = 86°C - 10°C = 76°C.

The mean radiator temperature is used in the normal way in conjunction with the designed room temperature and heat loss to determine the size of radiators required. (See radiator manufacturer's literature).

5.8.1 Pipework sizing

The circulating pump and the automatic system bypass are built into the appliance. The pump head available from the appliance at a flow rate corresponding to 20°C temperature difference is 2.5 m (8.4 feet). This is the pressure at which the automatic system bypass opens — see fig. 6.

System pipework should be sized such that the resistance of the circuit offering the greatest resistance to flow (the index circuit) does not exceed this figure.

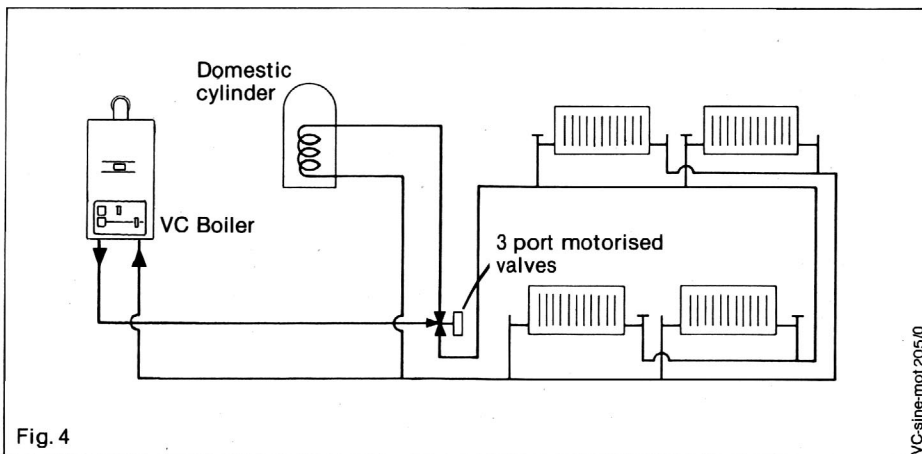

Fig. 4

5.9 System by-pass

A system bypass is included within the boiler. The boiler is suitable for use in systems with thermostatic radiator valves and no additional by-pass is required.

5.10 Open vented system

Refer to manufacturers for further details.

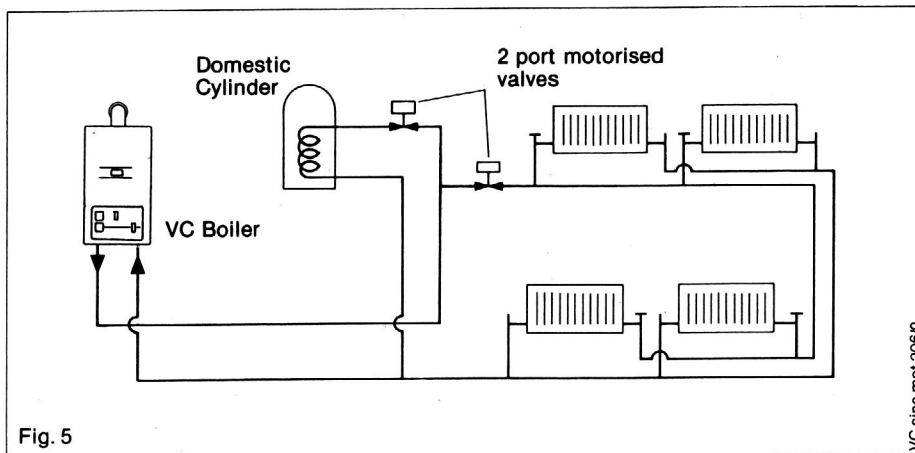

Fig. 5

VC-sine-mot 206/0

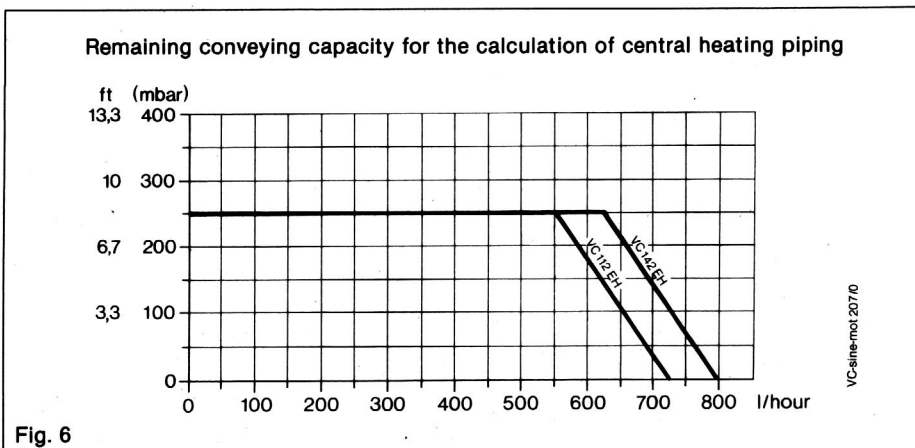

Fig. 6

VC-sine-mot 207/0

5.11 Sealed systems

Sealed systems do not require feed and expansion cisterns, open vents etc. Only good quality radiator valves and fittings should be used in order to prevent excessive detrimental topping-up.

5.11.1 Pressure relief valve

A pressure relief valve is provided ready-assembled to the return C.H. service cock (4, Fig. 14). This safety device is required on all sealed C.H. systems and is pre-set at 3 bar and is provided with a 3/4 in. BSP connection for a discharge pipe.

5.11.2 Pressure gauge

This is factory fitted to the boiler and indicates the primary circuit pressure to facilitate filling and testing.

5.11.3 Expansion vessel

An expansion vessel is incorporated into the boiler suitable for a sealed heating system with a maximum water contents of 90 litres (20 Imp. galls.).

If the nominal capacity of the built-in expansion vessel is not sufficient for the heating system (for instance in case of modernization of old open systems) an additional expansion vessel can be installed external to the appliance in the return pipe as close as possible to the boiler in accordance with BS 5449: Part 1.

Guidance on the sizing of an additional expansion vessel is given in Table A (p. 13).

5.12 Filling and make up (Fig. 7)

The system should be filled with water via a separate filling point fitted at a convenient point on the heating circuit. Where local Water Authority Regulation allows, a temporary connection to the mains may be used. The connection must be removed when filling is completed. Where local Water Authority Regulation does not allow temporary connection, a sealed system filler pump with break tank must be used.

In principle, sealed systems do not require water make-up facilities, but experience has shown that some make-up may be necessary.

Methods of filling sealed systems are given in appendix A of BS 6798 and BS 5449 Part 1.

5.13 Parallel installation

If two appliances are installed in parallel for one heating system, it is essential to install one nonreturn valve each in the heating system flow pipe of the appliances.

Refer to manufacturers for further details.

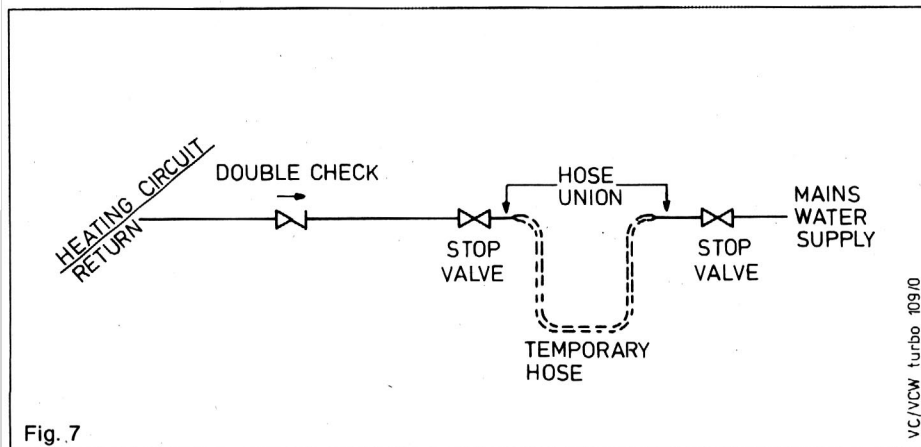

Fig. 7

5.14 Gas and water connection

A general view of pipework for gas and water connection is given in Fig. 8. The wall distance (to the finished wall) of pipework for gas and heating system is 50 mm.

5.15 Venting

The appliance is fitted with an automatic air vent. Additional provision should be made to enable the heating system to be vented during filling and commissioning either by automatic air vents or manually. Hydrosopic types of automatic air vents should not be used on a sealed system as these allow evaporation of small quantities of water.

- 1 Connection support bracket
- 2 Service cock (flow of heating system)
- 4 Union (gas)
- 5 Gas service cock (supplied with the boiler)
- 7 Service cock (return of heating system)
- 8 Discharge pipe
- 9 Pressure relief valve
- 10 Compression union (return of heating system)
- 11 Compression union (flow of heating system)
- 23 Frame of appliance (lower connection)

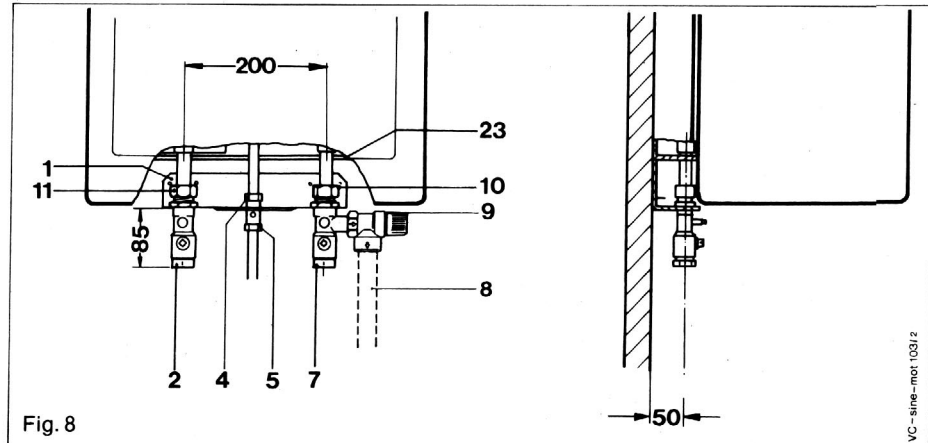

Fig. 8

Table A

Sizing of additional expansion vessels:

Safety valve setting (bar)	3,0								
Vessel charge pressure (bar)	0,5				1,0			1,5	
Initial system pressure (bar)	0,5	1,0	1,5	2,0	1,0	1,5	2,0	1,5	2,0
Total water content of system	Expansion vessel volume (litres)								
litres									
25	2,1	3,5	6,5	13,7	2,7	4,7	10,3	3,9	8,3
50	4,2	7,0	12,9	27,5	5,4	9,5	20,6	7,8	16,5
75	6,3	10,5	19,4	41,3	8,2	14,2	30,9	11,7	24,8
100	8,3	14,0	25,9	55,1	10,9	19,0	41,2	15,6	33,1
125	10,4	17,5	32,4	68,9	13,6	23,7	51,5	19,5	41,3
150	12,5	21,0	38,3	82,6	16,3	28,5	61,8	23,4	49,6
175	14,6	24,5	45,3	96,4	19,1	33,2	72,1	27,3	57,9
200	16,7	28,0	51,8	110,2	21,8	38,0	82,4	31,2	66,2
225	18,7	31,5	58,2	124,0	24,5	42,7	92,7	35,1	74,5
250	20,8	35,0	64,7	137,7	27,2	47,5	103,0	39,0	82,7
275	22,9	38,5	71,2	151,5	30,0	52,2	113,3	42,9	91,0
300	25,0	42,0	77,7	165,3	32,7	57,0	123,6	46,8	99,3
325	27,0	45,5	84,1	179,1	35,7	61,7	133,9	50,7	107,6
350	29,1	49,0	90,6	192,8	38,1	66,5	144,2	54,6	115,8
375	31,2	52,5	97,1	206,6	40,9	71,2	154,5	58,5	124,1
400	33,3	56,0	103,6	220,4	43,6	76,0	164,8	62,4	132,4
425	35,4	59,5	110,1	239,2	46,3	80,7	175,1	66,3	140,7
450	37,5	63,0	116,5	247,9	49,0	85,5	185,4	70,2	148,9
475	39,6	66,5	123,0	261,7	51,8	90,2	195,7	74,1	157,2
500	41,6	70,0	125,9	275,5	54,5	95,0	206,0	78,0	165,5
For system volumes other than those given above, multiply the system volume by the factor across	0.0833	0.140	0.259	0.551	0.109	0.190	0.412	0.156	0.331

The volume of the expansion vessel found from the above table, should be multiplied by 0,9 to take into account the flow temperature.

6 Dimensions

(all dimensions in mm)

- 1a Air/flue duct to the rear
- 1b Air/flue duct to the side
- 2 Appliance bracket
- 3 Heating system return $\frac{3}{4}$ " Rp ($\frac{3}{4}$ " B.S.P.)
- 5 Gas connection (15 mm)
- 7 Heating system flow $\frac{3}{4}$ " Rp ($\frac{3}{4}$ " B.S.P.)
- 8 Cable entry to the terminal box for external connections
- 9 Terminal box — electrical system
- 10 Wall outlet for electrical connections
- 11 Pressure relief valve $\frac{3}{4}$ " Rp ($\frac{3}{4}$ " B.S.P.)
- 12 Pre-assembled connection set with service cocks (flow and return) and pressure relief valve

- ¹⁾ Max 995 mm without extension
- Max 1980 mm with one extension
- Max 2965 mm with two extensions

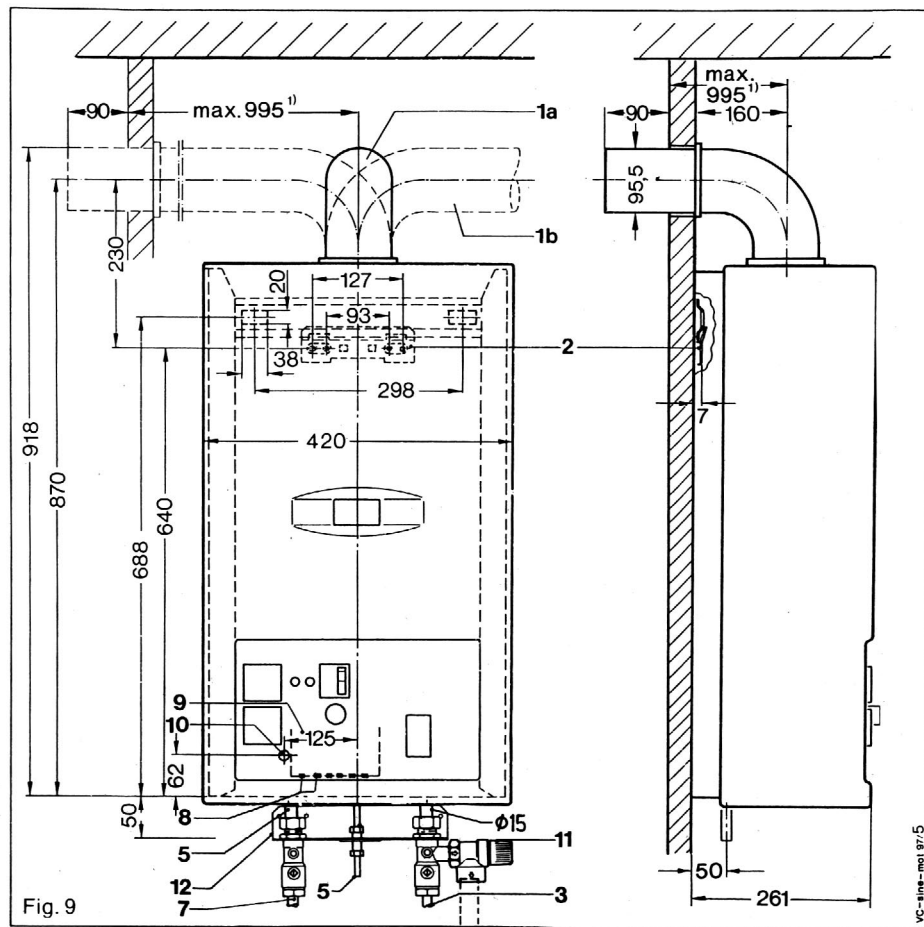

Fig. 9

VC-line-mot. 97/5

7 Installation of the boiler

7.1 General

The boiler is to be wall-mounted and a vertical flat area of wall is required which must be of sufficient area for the boiler together with clearances for installation and servicing.

The template provided includes these clearances which are:

25 mm (1 in.) either side of the boiler

170 mm (7 in.) below the boiler

255 mm (10,0 in.) on top of the boiler

Additional clearances than those given above may be necessary for installation, as this varies from site to site, it is left to the discretion of the installer.

If the appliance is to be fitted on a wall of combustible material, the wall must be protected by a sheet of fire proof material.

In addition, a minimum clearance of 500 mm (20 in.) must be available at the front of the appliance to enable the boiler to be serviced. Additional front clearance may be necessary if side clearances are restricted to enable the boiler case to be removed.

IMPORTANT NOTICE

If the boiler is to be fitted in a timber framed building it should be fitted in accordance with the British Gas publication 'Guide for Gas Installations in Timber Frame Housing'. Reference DM2. If in doubt advice must be sought from the Local Gas Region of British Gas.

7.2 Installation accessories

The connection accessories for the connection of the boiler are listed in the fig. 10.







Accessories	Order no.	
1) Pre-assembled connection group incl. isolating valves (flow and return), pressure relief valve	9319	
2) Air/flue duct assembly incl. terminal	300807	
Optional Extras	Order No.	
3) Extension (appr. 1 m) for the standard air/flue duct assembly	300802	
4) Additional 90° elbow	300808	
5) Additional 45° bends (pair)	300809	
6) Additional air/flue duct joint clamps (pair)	300806	
7) Se-duct flue kit	300810	
8) Terminal guard	9308 GB	

Fig. 10

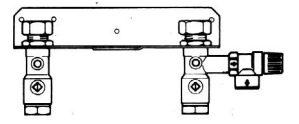
Note:

Should the terminal of the air/flue duct assembly need to be protected by a terminal

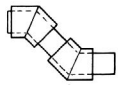
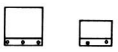
guard, a suitable guard is available from Vaillant Ltd. (Art. No. 9308 GB).

8 Delivery

The Vaillant boiler is delivered in three packages:

the cased boiler (item 1, fig 11),
pre-assembled installation set
(order-no.: 9319) and
the flue duct/terminal assembly
(order-no.: 300807)

The foam packing shells (2) contain the following:

- a) Front panel (3)
- b) Screen plate (4)
- c) Paper template (5)
- d) Installation instructions and user instructions (7)
- e) Gas service cock
- f) Wall bracket with fixing screws and wall plugs. Two special reducing nuts and reducing olives.
- g) The appliance (6)

Note: Lift boiler by the appliance frame not by the air/flue duct aperture.

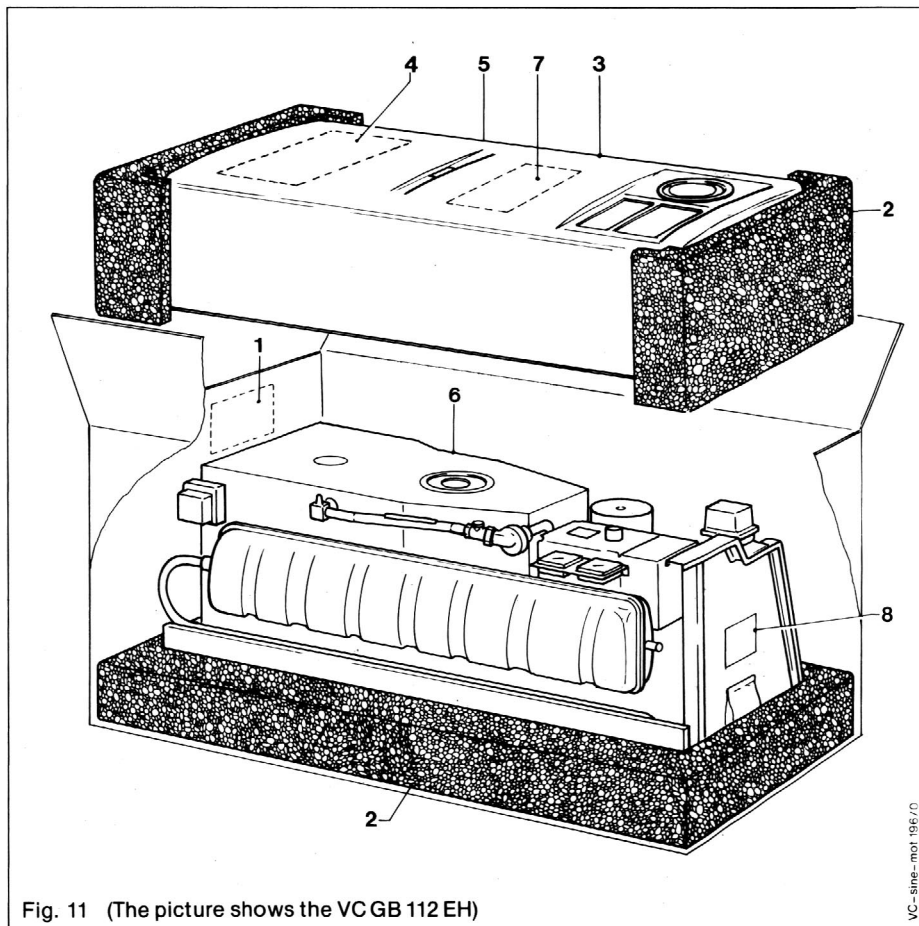

Fig. 11 (The picture shows the VCGB 112 EH)

VC-sine-mot 196/0

Check on the data plate (8) the appliance is the correct model for the gas supply.

9 Installation sequence

Using the template (fig. 12)

- Fix the template onto the selected position.

Check with a plumb line that the centre-line (C) of the template used is vertical. The template shows the appliance with necessary clearance around for servicing and air circulation.

Before proceeding check the following:

- a) the necessary air/flue duct length is in accordance with the installation options in section 1 of the instructions packed with the air/flue duct assembly.
 - b) the resulting terminal position is in accordance with section 5.5.
- Mark the position of the centre of flue duct (1) e.g. by drilling through. In the case of an installation with the air/flue duct to the rear of the appliance, mark the circumference of the hole, too.
 - Drill two holes (2) out of four fixing the appliance bracket as marked on the template with 8 mm (5/16 in.) diameter.
 - Drill three holes with 8 mm (5/16 in.) diameter (3) out of seven to fit the connecting group. Use the alternative fixing holes where necessary.

Drill through the wall with a 100 mm core drill to accept flue duct.

Refer to the air/flue duct installation instructions, Section 2, General, for full details.

- Remove the template from the wall and fit the mounting bracket in position (2) and the connecting group in position (3) using the wall plugs and screws provided ensuring both brackets are level. If the condition of the wall is poor, additional or alternative screw fixings will be required to ensure adequate support.

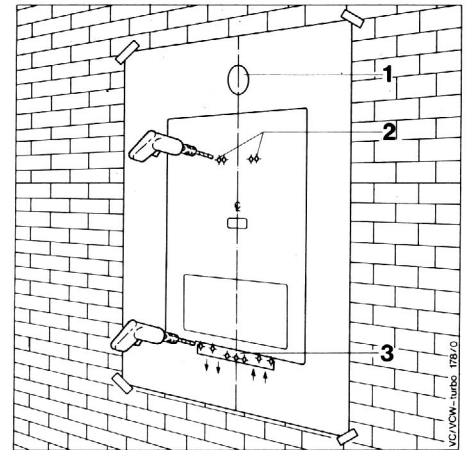

Fig. 12

9.1 Connection of heating system

Flush out all foreign matter from the flow and return pipe before connecting to the connection group.

Heating system flow and return should be connected to the connection group as shown in Fig. 13 via 3/4" B.S.P. adaptors.

Fill the heating system and test for soundness.

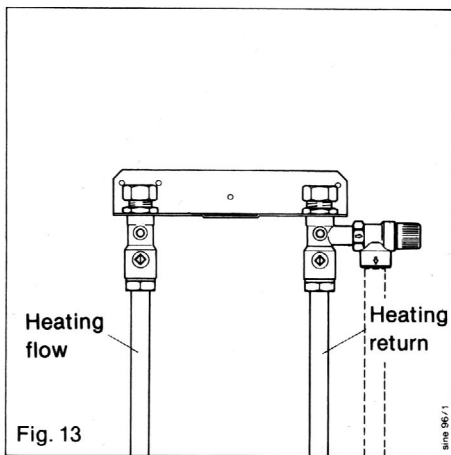

9.2 Pressure relief valve and overflow

The pressure relief valve (4), required for a sealed system, is included in the connection group 9319.

15 or 22 mm pipe should be connected to the pressure relief valve via a 3/4" B.S.P. adaptor. This discharge pipework should be as short as possible and installed with a continuous fall away from the boiler. The pipe should terminate in a position which ensures that any discharge of water or steam from the valve cannot create a hazard to persons in or about the premises, or damage to any electrical components or external wiring, and the point of discharge should be clearly visible. The discharge must not terminate above a window, an entrance or any type of public access. The installer must consider that the pipe could discharge boiling water.

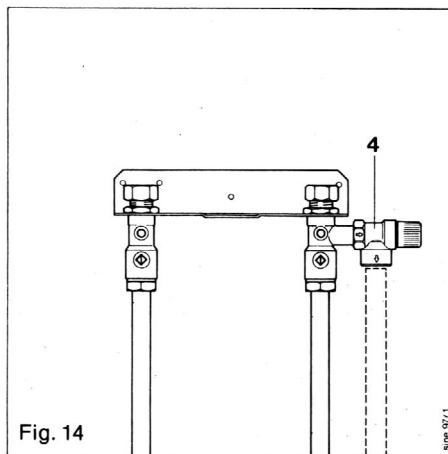

9.3 Air/flue duct

Before proceeding, refer to section 2 of the air/flue duct installation instructions and install the air/flue duct assembly.

9.4 Fitting the appliance

Close service cocks (5), unscrew union nuts (6) and take off the olive-shaped plastic plugs (7).

Unpack boiler from carton and remove packing aids as well as plastic caps from the connections.

Push union nuts (6) and reducing olives (7), (special size supplied with the boiler) onto the C.H. flow and return pipes of the appliance. Temporarily secure nuts and rings well clear of the ends of the pipes with tape. Mount the appliance by inserting the connection tubes into the C.H. service cocks on the connection group and hang the appliance with the crossbar (2) onto the appliance fixing bracket (3).

Remove tape and tighten union nuts (6).

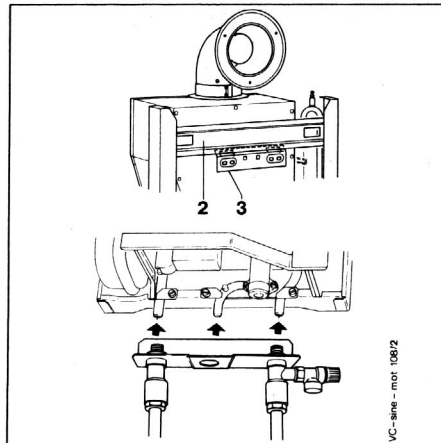
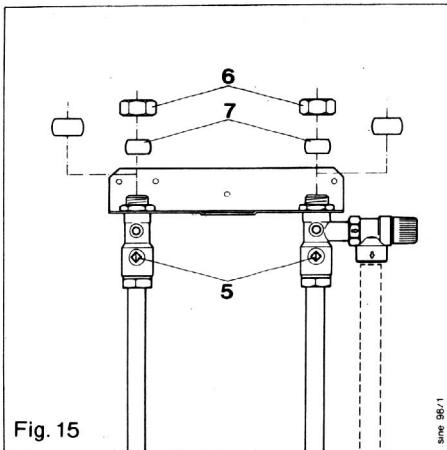

Fig. 16

9.5 Gas connection

Fit the gas service cock (5) to the appliance.

Ensure the gas service cock is fully located on the appliance and the ON/OFF control is accessible.

Clean out all foreign matter from the gas supply pipe before connecting to the service cock!

Connect the gas supply pipe to the service cock and tighten.

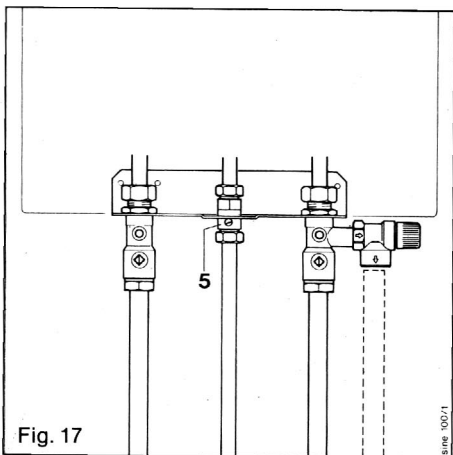

9.6 Connection of the air/flue duct to the appliance

Note :

Refer to the air/flue duct installation instructions for full details of installation of the air/flue duct.

This section is included for further reference only, in case the appliance has to be removed.

- Remove two screws (12, fig. 18) and take off one half-ring (13, fig. 18).

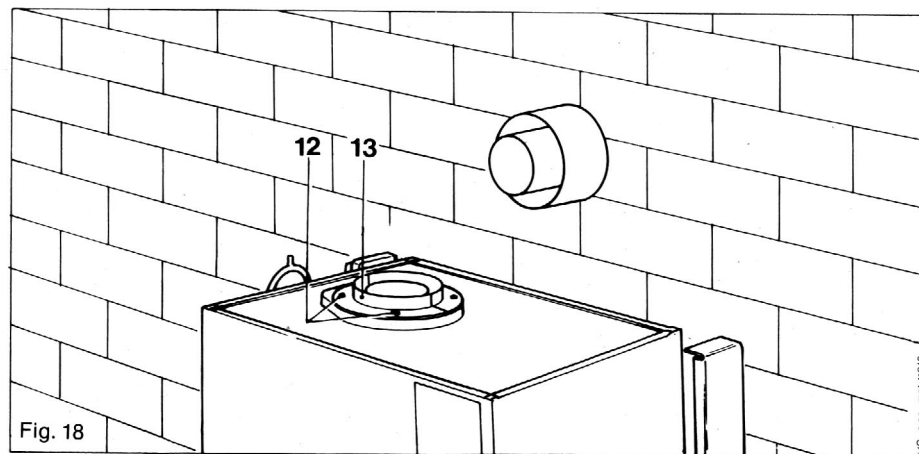

Place the 63 mm diameter x 35 mm wide flue duct clamp (14, fig. 19) loosely over the flue duct (1, fig. 19).

Place a 63 mm diameter x 22 mm wide flue duct clamp (24, fig. 19) over the flue gas connectin on the boiler.

Loosen screws on the 95 mm diameter x 55 mm wide clamp (17, fig. 21) and push over the air duct.

Remove screws and sealing washer on the 95 mm diameter x 25 mm wide clamp (16, fig. 21) and push onto the flue elbow on the side to be connected to the appliance. Ensure the clamp ring is clear of the end of the elbow.

Push the flue elbow into the clamp (24, fig. 20) connected to the appliance flue gas duct and tighten the securing screws lightly.

Ensure that the flue elbow and air/flue duct line up and are closely butted together. Pull the clamp (1, fig. 21) over the joint between the flue gas duct and the flue elbow. Ensure that the air/flue duct and terminal are correctly positioned. Tighten the securing screws on both flue duct clamps.

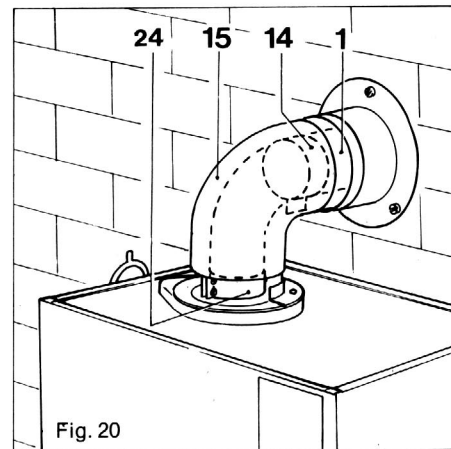
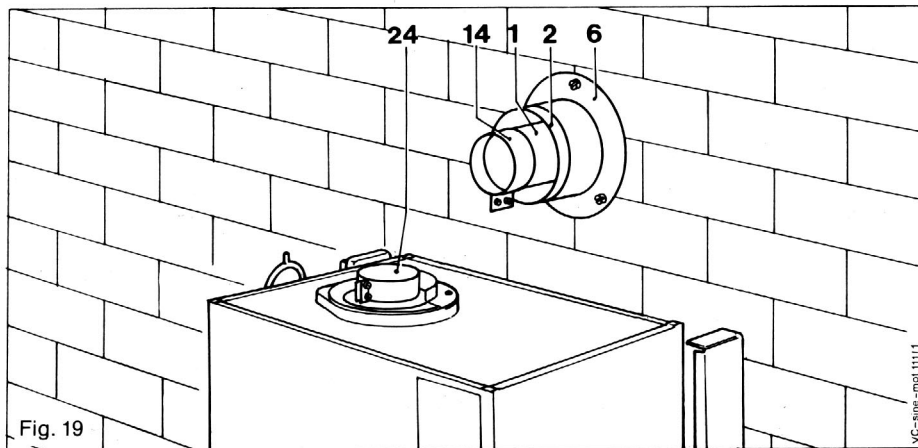

Refit the half ring (13, fig. 21) and two screws (12, fig. 21). Pull the 95 mm diameter x 25 mm wide clamp (16, fig. 21) over the joint between the flue elbow and the half rings. Refit the screws and sealing washer and tighten lightly.

Pull the 95 mm diameter x 55 mm wide clamp (17, fig. 21) over the joint between the flue elbow and the air/duct.

Tighten the screws on both air duct clamps.

Drill two holes, 3 mm diameter through both air duct clamps into the air ducts at the most convenient positions (28, fig. 21). Take care not to penetrate the inner flue duct. Screw the clamps to the inner flue duct. Screw the clamps to the air ducts using the self tapping screws provided.

Secure inner trim ring to wall using three screws provided.

Note: The trim ring is not essential. If it is not used make good the wall around the air/flue duct.

Make good the outside wall where necessary. Care should be taken that the mortar used in making good the outside wall does not block the air/flue duct assembly.

Fit the external trim ring over the flue terminal, mark and drill the position of three fixing holes and secure to the wall using the screws and wall plugs supplied.

Note: The external trim ring is not essential but if fitted will provide a neat finish to the hole cut through the wall.

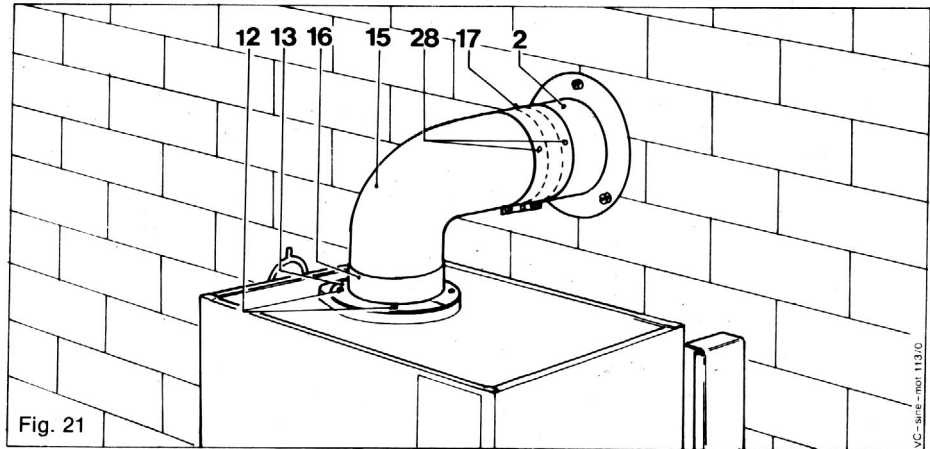

Fig. 21

VC-Serie-mod. 113.0

10 Electrical installation

The mains supply to the appliance must be 230-240 V~, 50 Hz, fused 3 A.

Warning! This appliance must be earthed.

The method of connection to the electricity supply must facilitate complete isolation and should preferably be via a fused, three-pin plug and unswitched, shuttered socket, both complying with the requirements of BS 1363. Alternatively, connection may be made via a fused, double-pole isolator having a contact separation of at least 3 mm in all poles and supplying the boiler and system controls only.

When connecting the power-supply cord, ensure that the length of the wires is such that the current-carrying conductors become taut before the earthing conductor should the cord slip from the cable clamp.

After removing the terminal box cover (1) connect the mains with the wire coloured blue to the terminal 1 (N) and the wire coloured brown to the terminal 2 (L) and the earth-wire coloured green and yellow to the terminal marked

A 3 core flexible cord according BS 6500 tables 6, 8 or 16 (3x0,75 to 3x1,5 mm²) should be used. A cardboard label showing the correct mains connection to the terminals is in the terminal box.

Do not connect the electrical main supply to the terminals 7, 8, 9!

Use the first left-hand cable clamp for the power supply cord.

Full wiring diagrams for various control schemes utilizing 2 and 3 port motorised valves are shown in fig. 23-28. Take care that the cords to the terminal box can not touch the hot water pipework, otherwise cords having a minimum appropriate T-rating of 90 shall be used. In the event of an electrical fault after installation, preliminary system checks i.e. earth continuity, polarity, resistance to earth shall be carried out.

List of terminals

Terminals	Connection
1, 2	Mains
3, 4	Switching connection for ext. controls (230-240 V~)
5	Neutral for ext. controls (230-240 V~)
7, 8, 9 (20V only)	N/A MUST NOT BE USED
10, 11, 12	

- | | |
|----------------------|-----------------------------------|
| 1 Terminal box cover | 10 Lock-out reset button |
| 2 Screw | 11 Lock-out red neon |
| 3 Terminal strip | 12 Fuses T 2 A |
| 4 Earth connection | 13 Pilot lamp "Operator on" |
| 5 Cable grip | 14 Pilot lamp "Diaphragm pump on" |
| 6 Cable grommet | 15 Fuse (T 0.16 A) |
| 7 Switch box | |
| 8 Screws | |
| 9 Screws | |

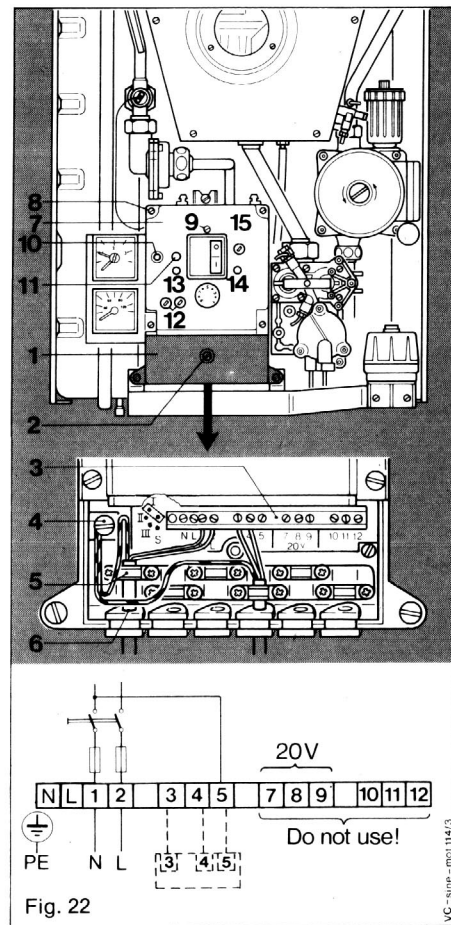

Connection details between programmer and wiring centre (3 port motorized valve systems)											
ACL. Lifestyle. LS 241, LS 522 & LS 722.											
					HW off	CH off	HW on	CH on			
	N	L	1	2	3	4					
	↓	↓	↓	↓	↓	↓	↓	↓	↓		
	5	3	8	NOT USED	7	6					
Drayton Tempus 3 Tempus 4 Tempus 7											
					HW off	CH off	HW on	CH on			
	E	N	L	1	2	3	4				
	↓	↓	↓	↓	↓	↓	↓	↓	↓		
	E	5	3	8	NOT USED	7	6				
Honeywell ST 7100. <i>Please Note: Link L-Com 3 & Com 6.</i>											
					CH off	CH on		HW off	HW on		
	N	L	com 3	4	5	com 6	7	8			
	↓	↓	↓	↓	↓	↓	↓	↓	↓		
	5	3		NOT USED	6		8	7			
Horstmann 525 & 527. <i>Please Note: Link L-2 & 2-5.</i> <i>* Please Note: Earth not required.</i>											
					HW on		HW off	CH on		CH off	
	E	N	L	1	2	3	4	5	6		
	↓	↓	↓	↓	↓	↓	↓	↓	↓	↓	
	*	5	3	7		8	6			NOT USED	
Landis & Gyr RWB 2, RWB 20 & RWB 40. <i>*Please Note: Neutral not required.</i>											
					HW off	CH off	HW on	CH on			
	N	L	1	2	3	4					
	↓	↓	↓	↓	↓	↓	↓	↓	↓		
	*	3	8	NOT USED	7	6					
Potterton EP 2000 & EP 6000. <i>Please Note: Link L-5.</i>											
					HW off	CH off	HW on	CH on			
	E	N	L	1	2	3	4	5			
	↓	↓	↓	↓	↓	↓	↓	↓	↓		
	E	5	3	8	NOT USED	7	6				
Randall 922 & 972. <i>Please Note: Link L-2 & 2-5.</i> <i>*Please Note: Earth not required.</i>											
					HW off		HW on	CH off		CH on	
	E	N	L	1	2	3	4	5	6		
	↓	↓	↓	↓	↓	↓	↓	↓	↓	↓	
	*	5	3	8		7	NOT USED			6	
Pegler SP 50 & SP 100. <i>Please Note: Link L-3.</i>											
					HW off	HW on			com	CH off	CH on
	1	2	L	N	E	S	S	3	4	5	
	↓	↓	↓	↓	↓	↓	↓	↓	↓	↓	↓
	8	7	3	5	E					NOT USED	6

Fig. 24

All external wiring must be carried out by a qualified electrician and be in accordance with the current I.E.E. Wiring Regulations.

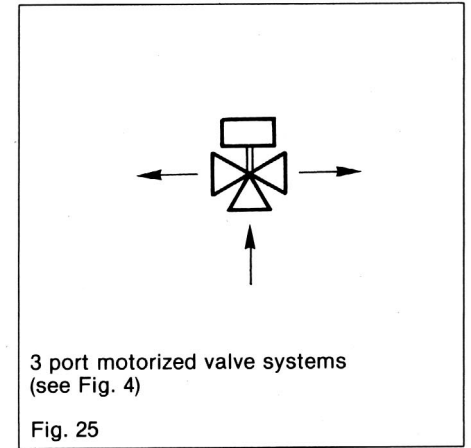

10.2.1 Connection details for systems utilizing two 2 port motorized valves

Important:

The arrowed numbers indicate connection into the relevant terminal on the wiring centre/junction box.

All external wiring must be carried out by a qualified electrician and be in accordance with the current I.E.E. Wiring Regulations.

10.3 Thermostatic radiator valves

where TRV's are used the pump control plug should be set to position II.

Frost protection

If a frost thermostat is fitted then it should be connected in parallel across terminals 3 and 4 on the boiler.

Diagram only applies to the specific controls mentioned.

3amp fused main supply

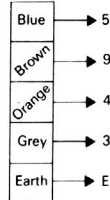
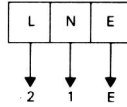

VAILLANT VC/VCW BOILER

Terminal Strip

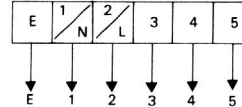

Wiring Centre/Junction Box *

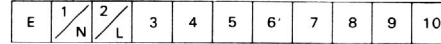

* DO NOT USE PRE-WIRED PRINTED CIRCUIT BOARD TYPE.

NOT USED

Programmer

For programmer connections see Fig. 27

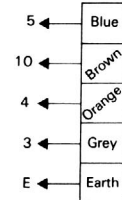
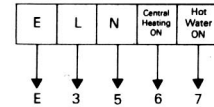

2 Port

Central Heating zone valve

ACL 679H308 30L1.

Drayton ZV 22.

Grasslin (Tower). MU2-3/4.

Honeywell V4043H.

Landis & Gyr SK2 (No Earth Required).

Pegler SZV 1212.

Potterton PMV2.

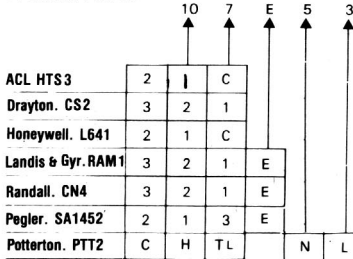

2 Port

Domestic Hot Water zone valve.

ACL 679H308 30L1.

Drayton ZV 22.

Grasslin (Tower). MU2-3/4.

Honeywell V4043H.

Landis & Gyr SK2 (No Earth Required).

Pegler SZV 1212.

Potterton PMV2.

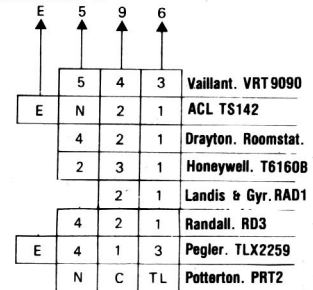

Fig. 26 Cylinder Thermostat.

Room Thermostat.

Connection details between programmer and wiring centre
(2 port motorized valve systems)

ACL. Lifestyle. LS 241, LS 522 & LS 722.

		HW off	CH off	HW on	CH on
N	L	1	2	3	4
↓	↓	NOT USED		↓	↓
5	3			7	6

**Drayton Tempus 3
Tempus 4
Tempus 7**

			HW off	CH off	HW on	CH on
E	N	L	1	2	3	4
↓	↓	↓	NOT USED		↓	↓
E	5	3			7	6

Honeywell ST 7100.

Please Note: Link L-Com 3 & Com 6.

			CH off	CH on		HW off	HW on
N	L	com 3	4	5	com 6	7	8
↓	↓		NOT USED	↓		NOT USED	↓
5	3			6			7

Horstmann 525 & 527.

Please Note: Link L-2 & 2-5.

** Please Note: Earth not required.*

			HW on		HW off	CH on		CH off
E	N	L	1	2	3	4	5	6
↓	↓	↓	↓		NOT USED	↓		NOT USED
.	5	3	7			6		

Landis & Gyr RWB 2, RWB 20 & RWB 40.

**Please Note: Neutral not required.*

		HW off	CH off	HW on	CH on
N	L	1	2	3	4
↓	↓	NOT USED		↓	↓
.	3			7	6

Potterton EP 2000 & EP 6000.

Please Note: Link L-5.

			HW off	CH off	HW on	CH on	
E	N	L	1	2	3	4	5
↓	↓	↓	NOT USED		↓	↓	
E	5	3			7	6	

Randall 922 & 972.

Please Note: Link L-2 & 2-5.

**Please Note: Earth not required.*

			HW off		HW on	CH off		CH on
E	N	L	1	2	3	4	5	6
↓	↓	↓	NOT USED		↓	NOT USED		↓
.	5	3			7			6

Pegler SP 50 & SP 100.

Please Note: Link L-3.

	HW off	HW on					com	CH off	CH on	
	1	2	L	N	E	S	S	3	4	5
	↓	↓	↓	↓				↓	↓	↓
NOT USED	7	3	5	E				NOT USED		6

Fig. 27

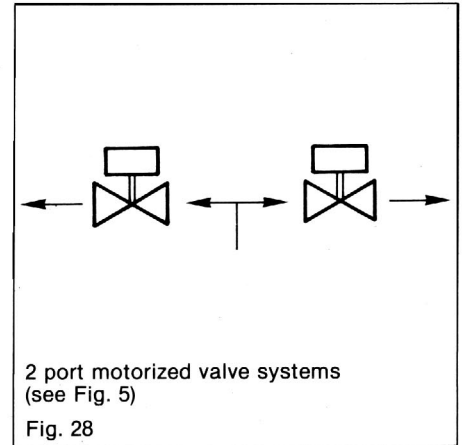

10.4 Operating modes of the system water circulating pump

In the factory, the heating system pump is set to operating mode (I) (electrical connection to contact I — see fig. 29).

By resetting the plug (1) to contacts I, II, III or S the following operating modes of the circulating pump become possible.

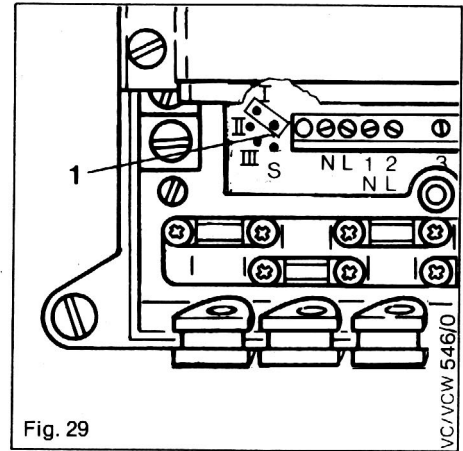

Fig. 29

Connection to:

<p>Contact I: (as supplied)</p>	<p>The pump is controlled by the external controls (only when connection is made across terminals 3 and 4).</p>
<p>Contact II:</p>	<p>The pump is controlled by the flow thermostat (electronic) only. After switching off the burner by the control, a pump over-run device will leave the pump running for about 20 seconds.</p>
<p>Contact III:</p>	<p>The pump runs continuously as long as the heating switch is on.</p>
<p>Contact S: (if fitted. This control is identified by the marking HY on the control box front cover)</p>	<p>The same as contact II but, after switching off the burner by the control, a pump over-run device will leave the pump running for about 5min (factory setting).</p>

11 Commissioning and testing

11.1 Electrical installation

Check the electrical installation by carrying out short circuit, earth continuity and resistance to earth tests and check for correct polarity.

11.2 Gas installation

The whole of the gas installation, including the meter, should be inspected and tested for soundness and purged in accordance with the recommendations of CP 331:3.

11.3 Central heating system

The whole of the system must be flushed out with both cold and hot water. Ensure all valves in the system and the appliance service cocks are open.

Open the stop cock gradually at the filling point connection to the central heating system until water is heard to flow. Do not open fully.

The system should be filled and air locks cleared. Starting with the lowest radiator open each air release valve closing it only, when clear water, free of bubbles, flows out. In the same way release air from any high points in the pipework.

For venting the boiler, back off the screw on the heat exchanger (1, Fig. 32) (see 13.4 to gain access), on the expansion vessel (5), and the circulating pump (2) by about 1-2 turns.

Fill the sealed system until the pressure gauge registers 1.5 bar (21.5 PSI).

After initial operation, once again drain the complete installation through the lowest point of the system to remove residues from the pipework.

In continuous operation, the appliance is vented automatically through the automatic air vent (3). It is for this reason **essential** that the cap (4) present on the top of the automatic air vent is **unscrewed** by about 1-2 turns and that it **remains** like that.

Refill system and check operation of pressure relief valve by lifting the lever or rotating the knob anticlockwise, where applicable. Release water from the system until the initial system pressure of 1.2 bar is attained.

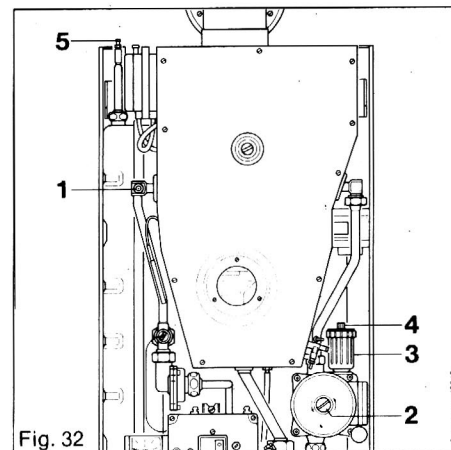

Fig. 32

(The picture shows the VC GB 112 EH)

11.4 Lighting the boiler

The first lighting of the appliance shall be done by a qualified fitter only. He shall also give clear verbal instructions to the user on how to operate the boiler, controls and systems generally as described separately in the "Instructions for use".

Turn on gas service cock. Ensure electrical supply is on. Ensure external controls are calling for heat.

Light the boiler by pushing main switch into position 1 (ON).

11.5 Gas soundness

In order to test the gas soundness of the burner gas connections it is necessary to temporarily operate the appliance with the inner case front panel removed.

Warning: Do not operate the appliance with the inner case front panel removed for more than a few seconds. Ensure adequate room ventilation. Shut down and refit inner case front panel immediately after completing gas soundness checks. Ensure that the inner case front panel is correctly fitted to obtain a good seal.

Pull the plastic tube off the connection TP (fig. 33). Do not remove any other pipes. Do not touch fan motor assembly or wiring. Turn on main switch and suck using mouth pressure on the plastic tube. This suction will operate the air pressure switch and the main burner will light. Squeeze tube to maintain suction whilst carrying out gas soundness test on burner and burner test point connections. Shut down appliance and refit tube. Refit inner case front panel (13.4). Check gas soundness of remaining integral gas components and joints with the main burner alight.

11.6 Test of flame supervision device (F.S.D.)

With the appliance running with the main burner alight, turn off the gas supply at the appliance service cock. The burner will extinguish and the ignition system will start sparking. After approximately 10 seconds, the appliance should shut down, the lock out black button on the control box should pop out and the red lock out neon should light.

Turn on gas service cock and push black button to reset.

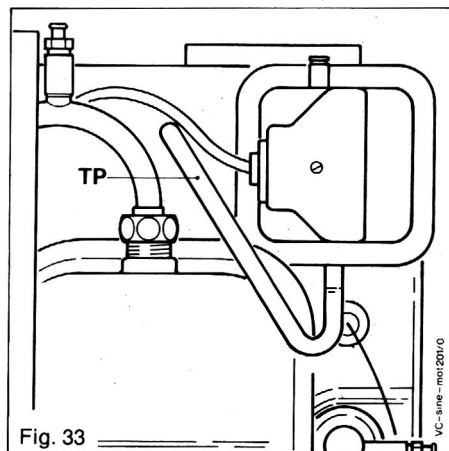

11.7 Gas pressure

11.7.1 Main burner pressure

The main burner gas pressure is factory set and sealed.

Therefore, it is not necessary to alter the setting during commissioning.

The main burner pressure is checked by connecting a pressure gauge to the main burner test point (fig. 34).

Disconnect the transparent lead from the NTC resistor by pulling off the cable connector (1, fig. 34). Operate appliance.

This will generate the maximum burner pressure on the modulating burner after a few seconds of operation which is 8.2 ± 0.8 mbar (VCGB 112EH) and 8.0 ± 0.8 mbar (VCGB 142EH).

If the burner pressure is incorrect, initially check that a 20 mbar gas inlet pressure is available at the inlet to the appliance with the appliance operating.

If the inlet pressure is less than 20 mbar, remedy external fault or contact Local Gas supplier. If the inlet pressure is correct at 20 mbar and the main burner pressure is incorrect, contact Vaillant Ltd.

Note: The main burner pressure immediately after ignition (ignition rate) will be only 1.9 ± 0.5 mbar (VCGB 112EH) and 1.5 ± 0.5 mbar (VCGB 142EH).

After a few seconds of appliance operation, the main burner pressure will automatically increase to the maximum rate of 8.2 ± 0.8 mbar (VCGB 112EH) and 8.0 ± 0.8 mbar (VCGB 142EH).

Reconnect N.T.C. cable connector.

11.8 Flow thermostat

Allow the C.H. System to warm up and adjust the position of the flow thermostat to check that the burner modulates down from high to low and low to off and vice versa (scale range covers about 35 to 90°C).

Note:

The appliance control incorporates a re-ignition delay to prevent rapid on-off cycling of the burner. This delay can be bypassed by briefly switching the main switch off and on again, so that the appliance-provided heat input is required-starts immediately after the main switch is switched on again.

11.9 Water soundness and final system flush

Allow the water system to reach maximum working temperature and examine for water soundness. The boiler should then be turned off and the C.H. system rapidly drained while still hot. The C.H. system should again be filled and cleared of air locks (see 11.3). Sealed systems should be adjusted to the initial system design pressure of 1.2 bar. The actual reading of the pressure gauge should ideally be 0.5 bar plus an additional pressure corresponding to the head of the highest point of the system above the base of the appliance, (10 m head equals an additional 1 bar reading on the pressure gauge), in any circumstances the minimum gauge reading should not be less than 1.0 bar. Finally set the red hand of the pressure gauge to 0.8 bar. Examine for water soundness.

Note:

If the system is to be treated with an inhibitor should be applied at this stage. Sentinel XI00 is suitable for this purpose and should be applied in accordance with the manufactures instructions. Further information can be obtained from Sentinel, Grace Dearborn Ltd. Tel. 0151 495 1861

11.10 Air/Flue duct assembly

Check visually the installation and function of the air/flue duct assembly.

11.11 Assemble appliance case (see chapter 12)

11.12 User's instructions

Hand the instructions for use to the user for retention and instruct in the safe operation of the appliance. Advise the user of the precautions necessary to prevent damage to the system and to the building if the system does not remain operative during frost conditions.

Finally, advise the user that for continued efficient and safe operation, this Vaillant appliance should be serviced at least once a year by a qualified servicing company. It is important and strongly recommended that arrangements are made for a MAINTENANCE AGREEMENT with a qualified servicing company to ensure regular servicing.

Please contact

Vaillant Service Department
(FREEPHONE 0800 318076)

for further details.

Note:

Leave installation and servicing instructions with the user when the installation is completed.

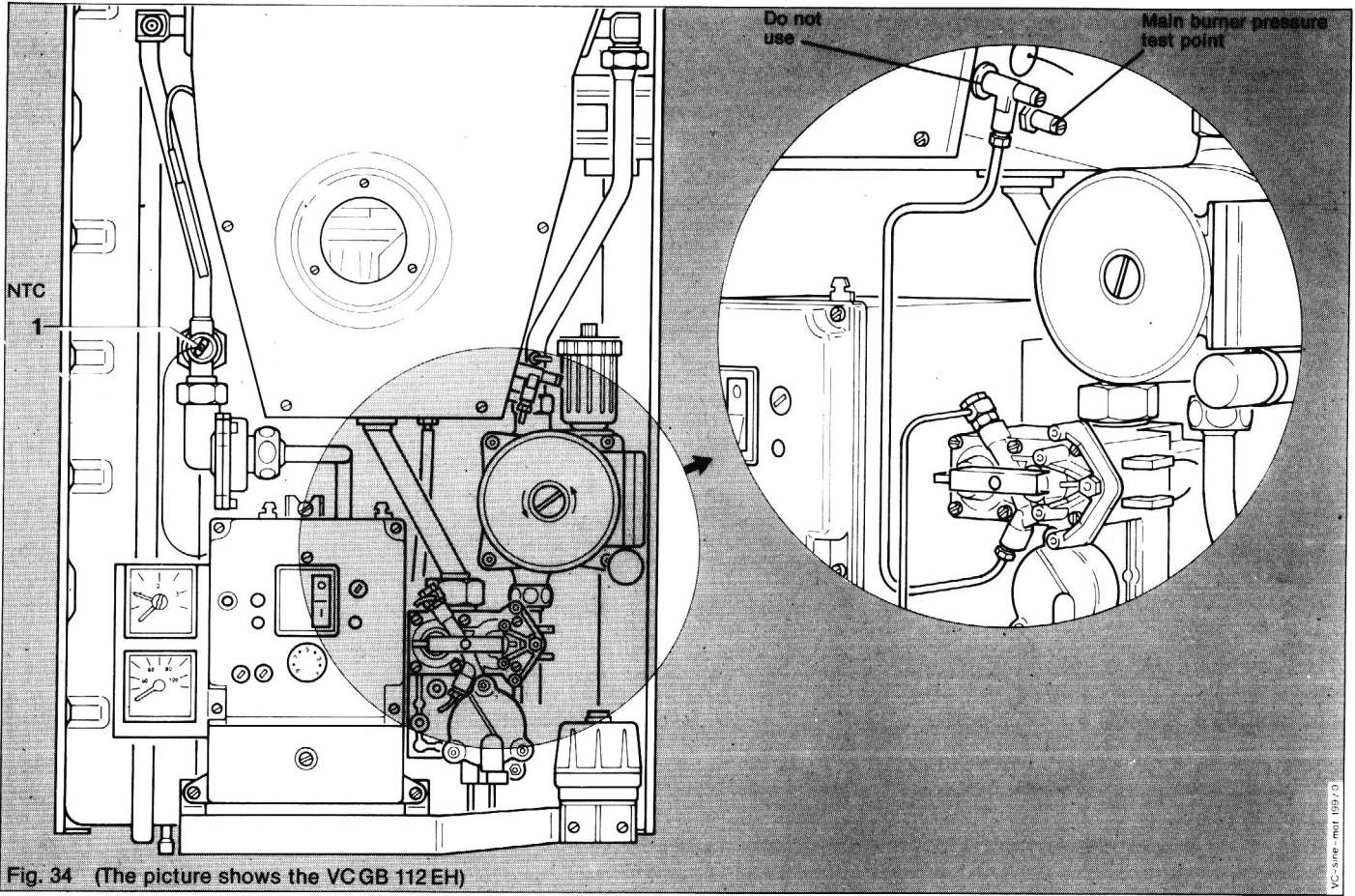

12 Assembling

Outer casing

Hook the outer casing (1) with the straps (2) on to the support (3).

Screen plate

Insert the screen plate (4) into the opening of the outer casing (1) and fasten with the screw (5).

- 1 Outer casing
- 2 Strap
- 3 Support
- 4 Screen plate
- 5 Screw
- 6 Temperature selector

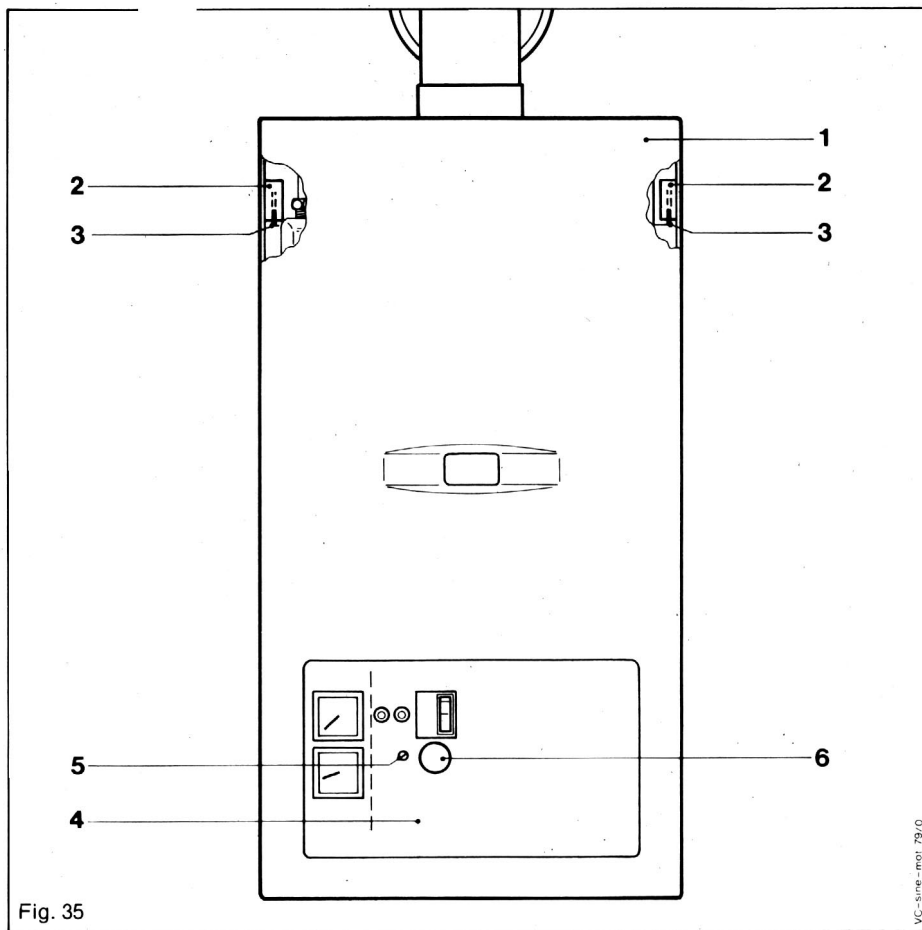

Fig. 35

13 Servicing of boiler

To ensure the continued safe and efficient operation of the boiler it is recommended that it is checked and serviced as necessary at regular intervals. The frequency of servicing will depend upon the particular installation conditions and usage, but in general once per year should be adequate. It is law that all servicing work is carried out by a competent person (Corgi registered).

IMPORTANT

Warning:

Before starting any maintenance work, switch OFF the mains electricity supply and disconnect the plug at the main isolating switch and socket. (If a switch is used, remove the fuse).

Turn OFF gas supply at the gas service cock fitted to the appliance. Always test for gas soundness after any service work and after exchanging any gas carrying component and always carry out functional checks.

Always after any service work and after exchanging any electrical component.

Check — earth continuity

- polarity
- resistance to earth.

To service the boiler follow the sequence 13.1 to 13.9

13.1 Inspection

13.1.1 Inspect exterior of the boiler, in particular the pipework, electrical connections and flue assembly for indications of damage or deterioration.

13.1.2 Inspect the air supply and ventilation arrangements of the installation ensuring that the requirements of 5.5 and 5.6 are met.

13.1.3 Operate the appliance (as shown in the instruction for use) at a high rate and inspect the burner operation through the viewing window. Check that the flames are of light blue colour and over all burner ports. Inspect for signs of yellowing, excessive lifting or sooting.

13.2 Turning off the boiler

- Isolate the electrical supply to the boiler
- Turn off gas service cock (2, fig. 36)
- Turn off boiler C.H. service cocks (3, fig. 36)

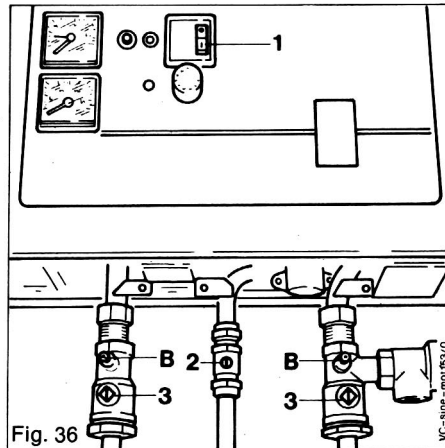

Fig. 36

13.3 Removing outer case (Fig. 35)

Remove the screen plate (4) from the opening of the outer casing (1) by unscrewing the screw (5).

Remove the outer casing (1) by lifting case upwards to disengage the straps (2) from the support (3).

13.4 Removing inner case (Fig. 37)

Remove the ten screws (A) to remove the inner case front panel.

Important:

When replacing the inner front panel it is essential that the panel is correctly fitted and a good seal obtained.

(The picture shows the VC GB 112 EH)

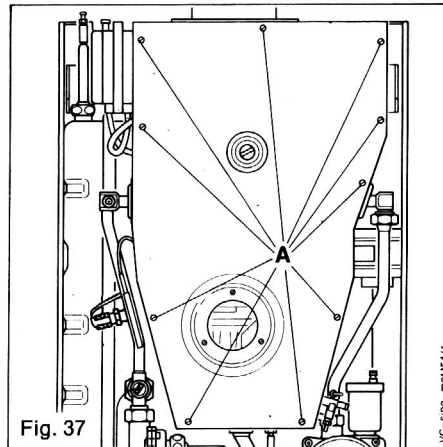

13.5 Cleaning of burner

(Fig. 38)

Remove 4 screws securing burner skirt.

Remove red high tension leads (HT) from spark electrodes and transparent cable (FS) from flame sensing electrode.

Remove the two screws (S) and lift burner up and out.

Disconnect both ends of burner test point extension (E) and remove. Remove burner bar fixing screws (BS).

Remove burner bar (BB) by pulling forward.. Clean burner and injector nozzles with a light brush or a vacuum cleaner.

(The picture shows the VCGB 112 EH)

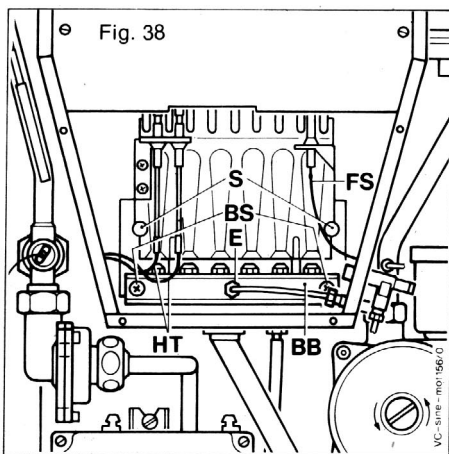

13.5.1 Cleaning of burner

(VCGB 142 EH), Fig. 38.1

Remove 4 screws securing burner skirt.

Remove red high tension leads (HT) from spark electrodes and transparent cable (FS) from flame sensing electrode.

Remove the middle screw (S) and lift burner up, forward and out.

Disconnect both ends of burner test point extension (E) and remove. Remove burner bar fixing screw (BS) and clamp. Remove burner bar (BB) by pulling forward. Clean burner and injector nozzles with a light brush or a vacuum cleaner.

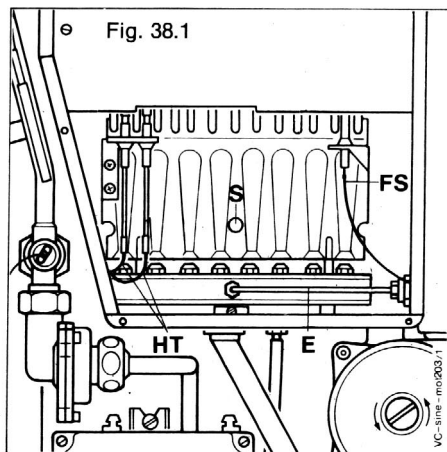

13.6 Cleaning of main heat exchanger

(Fig. 39)

Unscrew fixing screws (2).

Remove front cover (3).

Inspect bottom of heat exchanger through the combustion chamber using a torch and clean if necessary with a stiff long bristle brush.

Gain access to the top of the heat exchanger by removing the fan (see 14.8) and flue hood. Inspect heat exchanger and clean if necessary using a stiff long bristle brush. Reassemble in reverse order.

(The picture shows the VCGB 112 EH)

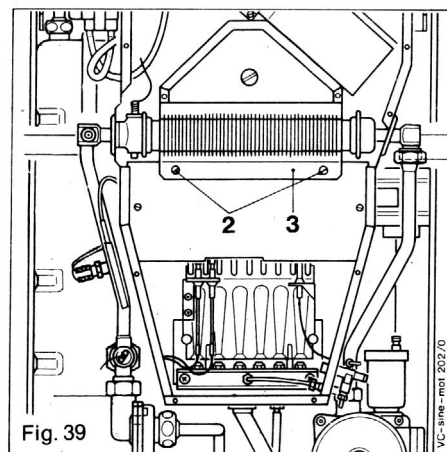

13.7 Check of C.H expansion vessel

Close C.H. service cocks (3, Fig. 36)

Release pressure from the appliance as described in 14.17.

Remove protective cap.

Check internal pressure of expansion vessel which should be 0.7 to 0.9 bar. Repressurise the expansion vessel as necessary using an air pump. (Fig. 40).

Open C.H. Service cocks and repressurise C.H. System if necessary.

(See appropriate paragraphs of 11.9)

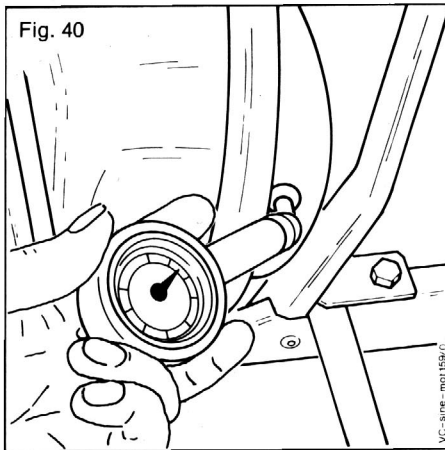

13.8 Cleaning of water filter (C.H. return) (Fig. 40a)

Unscrew the cap of the filter housing.

Gain access by removing the overheat cut off device (2 screws, Rs, fig. 57) if necessary.

Slide out the filter and clean.

Replace filter ensuring that the two lugs on the side of the filter engage in the two slots inside the filter housing.

Replace cap taking care to ensure threads are correctly engaged and tighten by hand. Do not overtighten.

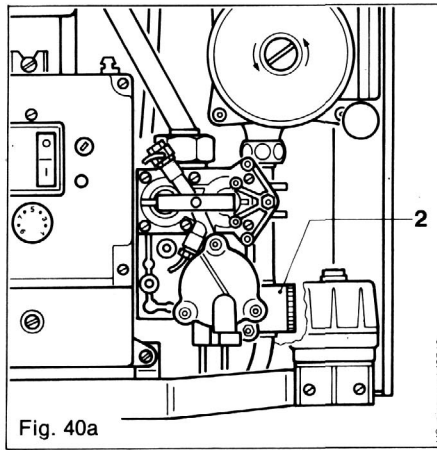

13.9 Recommissioning the appliance

- a) Refit inner case
- b) Reconnect electrical supply
- c) Turn on gas service cock
- d) Operate burner with inner case front panel removed in order to test gas soundness of burner and burner test point connections (11.5)
- e) Refit inner case front panel (13.4). Ensure the panel is correctly fitted and a good seal is obtained.
- f) Light the boiler (see 11.4).
- g) Check gas soundness of remaining gas connections (11.5)
- h) Check gas pressure (11.7)
- i) Test flame supervision device (11.6)
- j) Test C.H. flow thermostat (11.8)
- k) Check water soundness (11.9)
- l) Check air/flue duct assembly (11.10)
- m) Carry out electrical test (11.1)
- n) Refit outer case (12)

14 Replacement of parts

General

Before starting any replacement of parts, switch OFF the main electricity supply and disconnect the plug at the main isolating switch and socket. (If a switch is used, remove the fuse).

Turn off gas supply at the gas service cock. Always test for gas soundness after any service work and after exchanging any gas carrying component.

Always carry out functional checks.

After breaking any internal electrical circuit check — earth continuity

- polarity
- resistance to earth.

14.1 Change of electrodes (Fig. 41)

Remove outer case and inner case (13.3 and 13.4).

Pull off the two red high tension leads (HT) or the transparent sensor lead as appropriate.

Remove the burner retaining screws (S, VCGB 112 EH) or (S, VCGB 142 EH, Fig. 38.1) and lift out burner (B). Remove fixing screw for the electrode assembly. Replace electrode assembly and reassemble in reverse order.

(The picture shows the VCGB 112 EH)

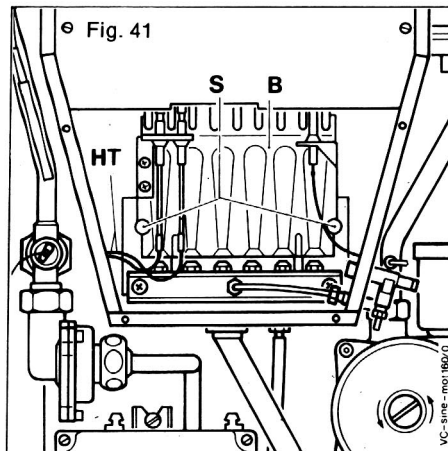

14.2 Change of NTC resistor (Fig. 42)

Remove outer case as under 13.3.

Disconnect the push on connector and unscrew the NTC probe.

Reassemble in reverse order.

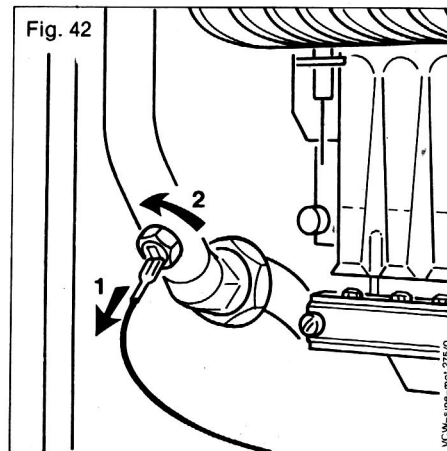

14.3 Change of automatic air vent (Fig. 43)

Remove outer case as under 13.3

Release system pressure as under 14.17.

Unscrew the automatic air vent by hand. Reassemble in reverse order, screwing in the automatic air vent by hand only.

Open the locking cap (LC) of the automatic air vent by 1—2 turns.

Reassemble casing in reverse order and repressurise system.

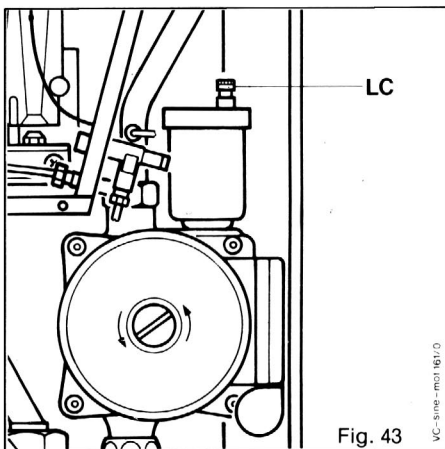

14.4 Gas section

Access to the gas section can be improved as follows:

Release gauges by removing bottom left screw on control box (BS, Fig. 49). Remove 3 screws (RS, Fig. 49) and ease control box forward. Further access can be gained by removing the two screws (RS, Fig. 57) and moving the overheat out-off device to the R.H.S

14.4.1 Change of operator (Fig. 44)

Turn off boiler as under 13.2

Remove outer case as under 13.3.

Isolate the appliance from the electrical mains and pull off the cable connectors (P) from the operator (O).

Disconnect the control lines (CL) by unscrewing retaining bolt (RB) and union nut (UN). Unscrew the four retaining screws (RS).

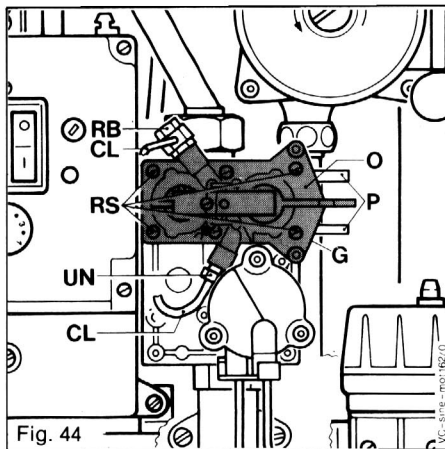

Reassemble in reverse order using new gasket (G). Check for gas soundness. Carry out electrical checks (11.1). Check burner pressure (11.7).

14.4.2 Change of gas section (Fig. 45)

Turn off boiler as under 13.2.

Remove outer case as under 13.3.

Release system pressure in C.H side as under 14.17.

Isolate the appliance from the electrical mains and pull off the connectors (P) from the operator (O).

Disconnect the two control lines (CL) by unscrewing the retaining bolt (RB) and the union nut (UN).

Note the connection of the two control lines to the differential valve. Note the connections of the other ends of these control lines. Remove clamp (BR) by sliding sideways.

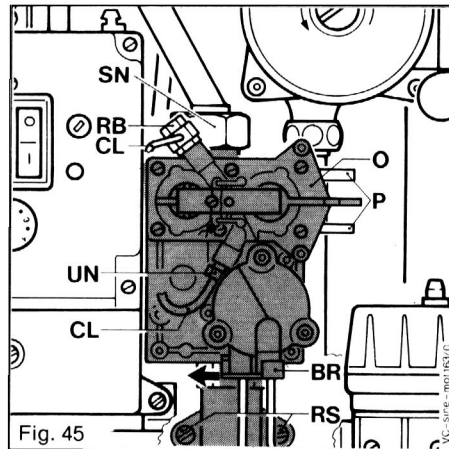

The control lines are a push fit into the differential valve. (Disconnect connections of the other ends of the control lines to gain movement as necessary. Ensure all connections are noted to assist reassembly).

Remove the two retaining screws (RS) and loosen the sleeve nut (SN).

Reassemble in reverse order using new washers. Check connections for gas soundness. Carry out electrical checks (11.1).

Check burner pressure (11.7).

14.4.3 Change of differential valve (Fig. 46)

Turn off boiler as under 13.2.

Remove outer case as under 13.3.

Release system pressure in C.H. side as under 14.17.

Note connections of the two control lines to the differential valve. Note the connections of the other ends of these control lines. Remove clamp (C) by sliding sideways. The control lines are a push fit into the differential valve. (Disconnect connections at the other ends of the control lines to gain movement as necessary. Ensure all connections are noted to assist reassembly). Unscrew the three retaining screws (RS).

Reassemble in reverse order.

Repressurise appliance.

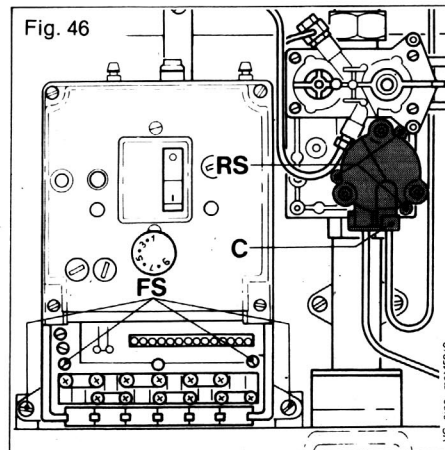

14.4.4 Change of gas section stuffing box (Fig. 47)

Remove the differential valve as under 14.4.3.

Unscrew the stuffing box (SB) taking care not to bend the pin.

Reassemble in reverse order, using new washers.

Check connections for gas soundness.

14.5 Change of pump (Fig. 48)

Turn off the appliance 13.2.

Remove outer case as under 13.3.

Drain C.H. side of appliance (14.17 and 14.18).

Unscrew the automatic air vent by hand.

Unscrew the two unions (U) of the pump.

Open terminal box of the pump.

Note the colour code of wiring and disconnect cable.

Reassemble in reverse order using new washers and repressurise system.

Carry out electrical checks (11.1).

14.6 Control box

14.6.1 Opening control box (Fig. 49)

Remove outer case as under 13.3.

Isolate the appliance from the electrical mains. Open the terminal box by removing the retaining screw (TS). Mark the wiring and remove it from the terminal block. Remove the four retaining screws (BS). Pull out slowly the control box cover complete with the switch board and printed circuit boards.

Pull off the multiple plugs from the PC boards. Reassemble the control box in reverse order.

When replacing the screws, position the star washer under the left top screw.

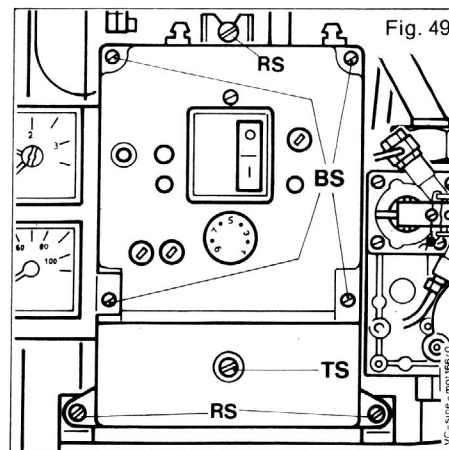
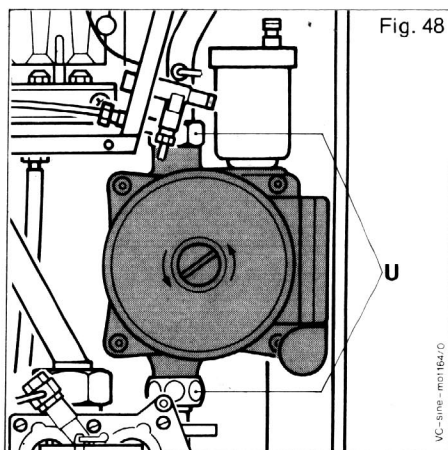
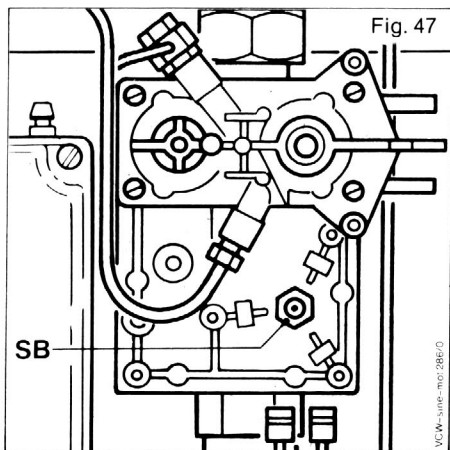

14.6.2 Change of fan control circuit board (F.C.C.B.) (Fig. 50)

Take off control box cover as under 14.6.1.

Unscrew the two retaining screws (RS) or push out the plastic retaining clips (where fitted) and remove FCCB from the main switch circuit board by lifting up.

Reassemble in reverse order.

Carry out electrical checks (11.1).

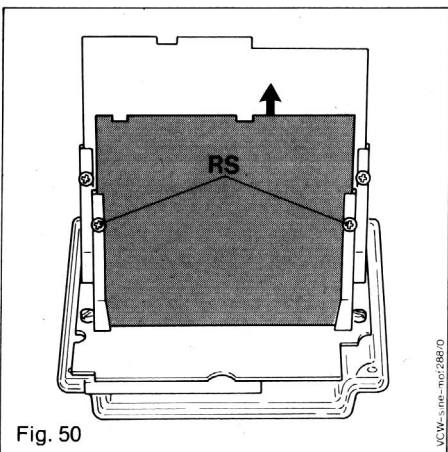

Fig. 50

14.6.3 Change of electronic thermostat circuit board (T.C.B.) (Fig. 51)

Take off control box cover as under 14.6.1 and F.C.C.B. as under 14.6.2. Pull off temperature selector knob (6, fig. 35).

Unscrew the two retaining screws (RS) or push out the plastic retaining clips (where fitted) and remove T.C.B. from main switch circuit board by lifting up.

Reassemble in reverse order.

Carry out electrical checks (11.1).

Check operation of C.H. flow thermostat (11.8).

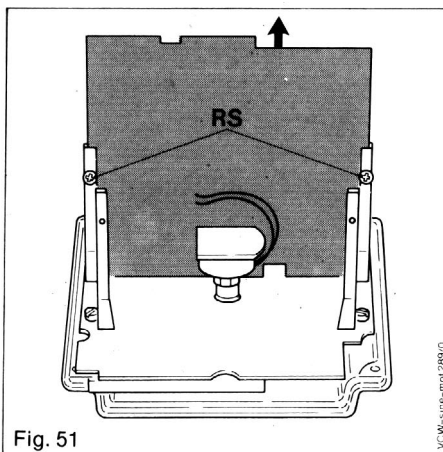

Fig. 51

14.6.4 Change of flame supervision circuit board (F.S.C.B.) (Fig. 52)

Take off control box cover as under 14.6.1 and remove connections (C) of lock out red neon from F.S.C.B.

Unscrew retaining nut from lock out reset bottom (RN).

Disengage lock out reset button from control box cover and carefully unhook F.S.C.B.

Reassemble in reverse order.

Carry out electrical checks (11.1).

Check operation of flame supervision device (11.6).

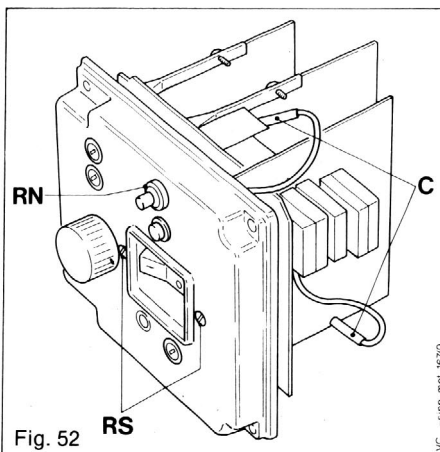

Fig. 52

14.6.5 Change of main switch circuit board (M.S.C.B.) (Fig. 53)

Carry out operations 14.6.1, 14.6.2, 14.6.3 and 14.6.4.

Unscrew the two retaining screws (RS) as well as the two retaining screws (RS, fig. 52).

Reassemble in reverse order.

Carry out electrical checks (11.1).

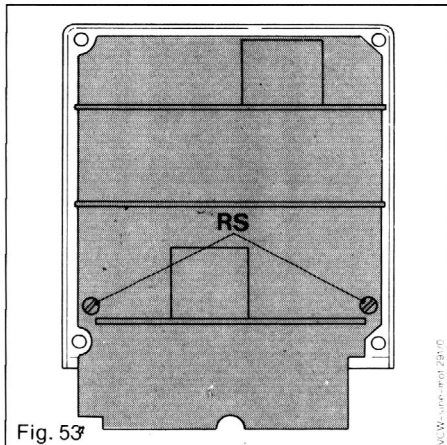

14.6.6 Change of diaphragm pump (Fig. 54)

Remove outer case as under 13.3.

Isolate the appliance from the electrical mains. Open the main terminal box (screw TS, fig. 49).

Unscrew the four retaining screws (FS, fig. 46), and top screw (RS, Fig. 49). Pull out complete control box to the front.

Mark and disconnect plastic hoses (PH) and push on connectors (AP).

Pull out diaphragm pump with rubber legs (RL) from control box bottom.

If necessary, access to the rubber legs inside the control box can be achieved by sliding out the control box cover completely with printed circuit boards (14.6.1).

Reassemble in reverse order.

Carry out electrical checks (11.1).

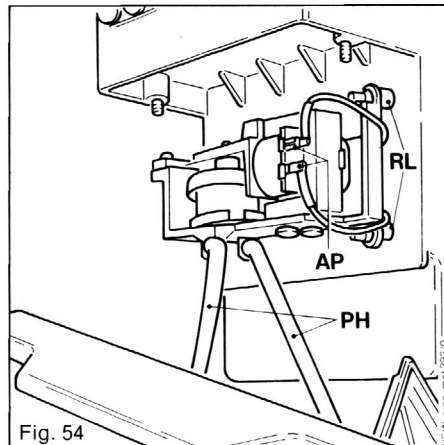

14.6.7 Change of ignition transformer (Fig. 55)

Isolate the appliance from the electrical mains.

Unscrew 3 retaining screws (RS, fig. 49), securing the control box to appliance chassis. Pull complete box forward — the retaining chain will support the box.

Gently rotate box to gain access to the ignition transformer and remove retaining screw (RS, fig 55).

Note position of the cable connectors. Pull off high voltage leads (HVL), remove cable connectors and remove fixing screws (FS).

Reassemble in reverse order.

Carry out electrical checks (11.1).

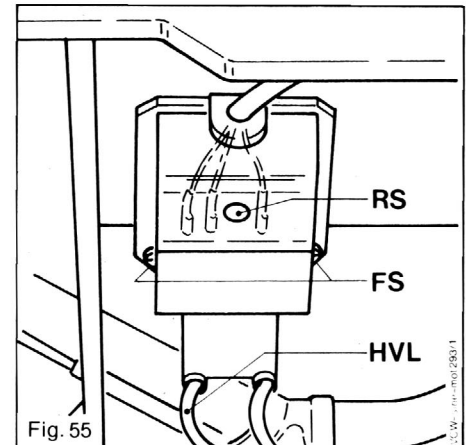

Note:

Ensure that the earth cable (green/yellow) is connected to the earth terminal on the transformer.

14.7 Change of overheat cut-off device
(Fig. 56)

Isolate the appliance from the electrical mains.

Remove outer and inner case as under 13.3 and 13.4.

Remove wire loop retaining the temperature sensor (TS) in the sensor pocket. Slide sensor upwards out of the pocket and draw through the rubber seal (S) in the side plate.

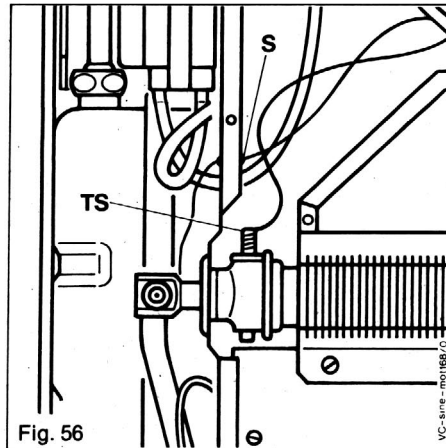

Remove the two retaining screws (RS, Fig. 57) and open protective housing (H) with screw driver in the slot between the two halves of the protective housing (fig. 57).

Unscrew the two fixing screws (FS). Clear overheat cut-off device from housing. Remove cable connectors.

Reassemble in reverse order.

Check — earth continuity
— polarity
— resistance to earth.

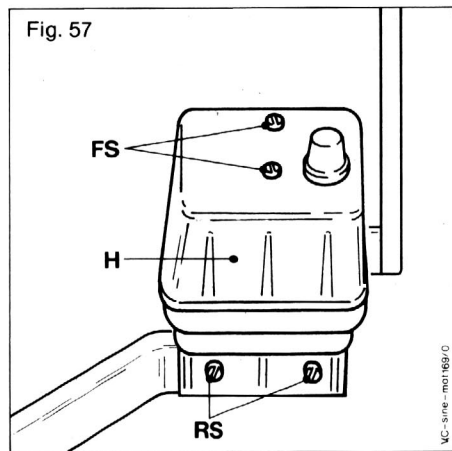

14.8 Change of fan (Fig. 58)

Isolate the appliance from the electrical mains.

Remove outer and inner case as under 13.3 and 13.4.

Remove 2 fixing screws (FS), washers and gasket.

Gently move clamping to one side.

Remove 3 retaining screws (RS).

Note position of cable connectors on fan motor and remove.

Slide flue hood and fan assembly forwards carefully and remove.

Reassemble in reverse order.

Carry out electrical checks (11.1).

To dismantle the fan from the flue hood remove 3 retaining screws (RS, fig. 59).

Reassemble in reverse order.

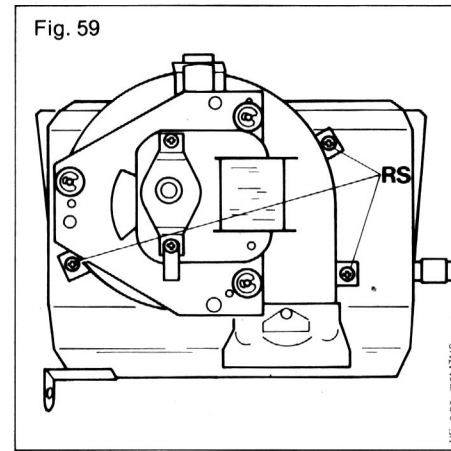
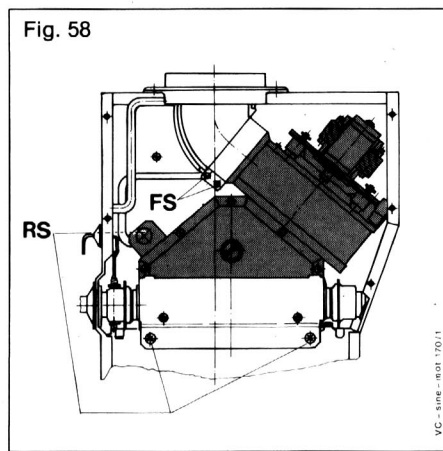

14.9 Change of air pressure switch (Fig. 60)

Isolate the appliance from the electrical mains.

Remove outer and inner case as under 13.3 and 13.4.

Remove the fixing screw (FS) and take out air pressure switch from the left side.

Remove protective cover by unscrewing retaining screw (RS, Fig. 61).

Note position of cable connectors (A) and remove cable.

Mark and disconnect plastic hoses (PH).

Reassemble in reverse order.

- Check — earth continuity
- polarity
- resistance to earth.

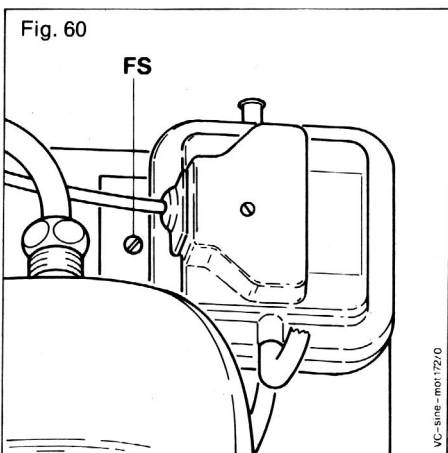

14.10 Change of expansion vessel (Fig. 62, 63)

In the unlikely event of a failure of the CH expansion vessel:

Turn off the boiler (13.2).

Remove outer case as under 13.3.

Release CH system pressure as under 14.17.

Temporarily remove cable connectors (9, Fig. 67).

Remove the lower left retaining screw (BS) as under 14.6.1.

Take off the thermometer and manometer case. Loosen the retaining screw (RS, Fig. 62 and the sleeve nut (SN, Fig. 62).

Take out expansion vessel as shown in Fig. 63.

Reassemble in reverse order using new washers.

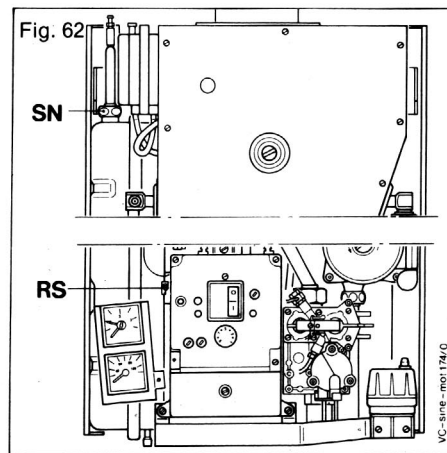
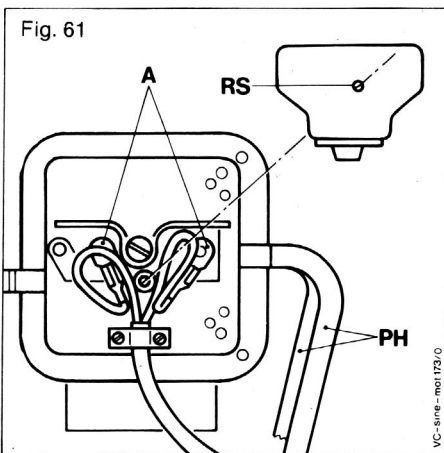

14.11 External replacement vessel

Alternatively, a suitable replacement expansion vessel can be fitted external to the boiler as described in 5.11.3

In these circumstances, the replacement expansion vessel must be correctly sized, ignoring the original expansion vessel which can be left in position on the boiler.

(The picture shows the VC GB 112 EH)

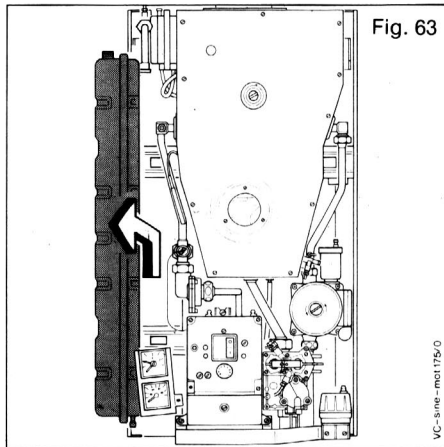

14.11.1 Change of thermometer (Fig. 64)

Remove outer case as under 13.3.

Pull the temperature sensor (TS) out of the sensor tube.

Remove the lower left retaining screw (BS) as under 14.6.1.

Press the two tongues into the thermometer and pull it out to the front side.

Reassemble in reverse order.

(The picture shows the VC GB 112 EH)

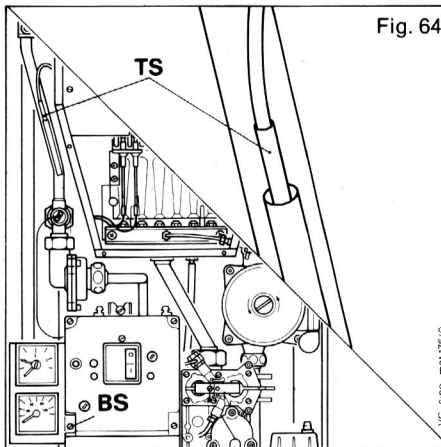

14.12 Change of pressure gauge (Fig. 65)

Remove outer case as under 13.3.

Release CH system pressure as under 14.17

Disconnect the tubing nut (TN) of the control line. Lift the gauge out from the bracket upwards.

Reassemble in reverse order.

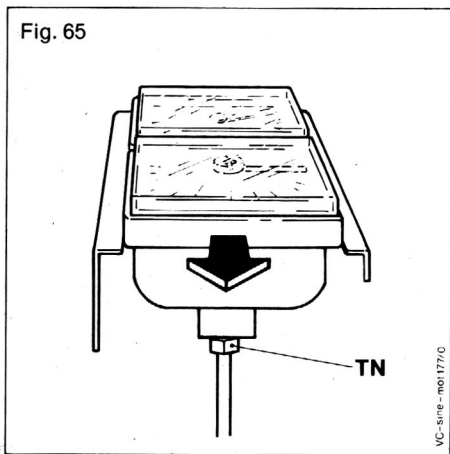

14.13 Change of system bypass (Fig. 66)

Remove outer case as under 13.3.

Release CH system pressure and drain boiler as under 14.17 and 14.18

Unscrew the two union nuts (U) and remove valve.

Unscrew the three screws holding the top of the valve. Renew diaphragm or spring as necessary. Do not move spring adjusting nut.

Reassemble in reverse order using new washers.

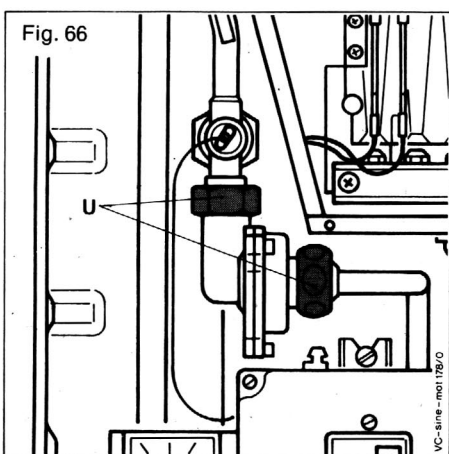

14.14 Change of central heating overhear thermostat

The thermostat is located on the CH flow pipe on the LHS of the boiler (9, fig. 67).

Remove the cable connectors.

Unscrew the thermostat from the flow pipe.

Reassemble in reverse order.

Do not overtighten the thermostat.

14.15 Change of central heating pressure relief valve

Turn off the boiler as under 13.2.

Remove the outer case as under 13.3.

Release CH system pressure as under 14.17

Remove the discharge pipe connection.

Unscrew the pressure relief valve from the return central heating service cock.

Reassemble in reverse order.

14.16 Change of main heat exchanger and combustion chamber insulated duct (Fig. 67)

- Remove outer case as under 13.3 and inner case as under 13.4.
- Release C.H. system pressure as under 14.17.
- Drain boiler as under 14.18.
Remove phial (1) of the overheat cut-off device from the pocket in the heat exchanger.
- Remove fixing screws (2).
- Remove front cover (3).
- Pull off cable connector on NTC sensor (4).
- Pull off cable connectors on C.H. overheat thermostat (9)

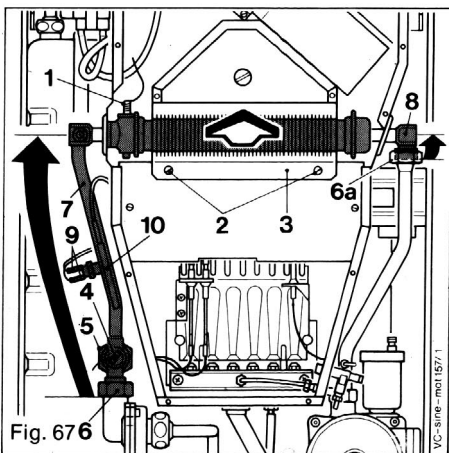

- Pull out temperature gauge sensor from pocket on flow pipe (10).
- Lift upwards wire security clip on flow pipe (5). Disconnect union nuts 6 and 6a.
- Rotate flow pipe (7) and return pipe (8) through 90° towards the front and disconnect the bayonet joints from the heat exchanger.
Slide heat exchanger out forwards.
Remove fan (see 14.8).
Remove burner skirt (4 screws).
Release the screw each side and lift combustion chamber duct up and out.
Reassembly in reverse order taking care to correctly locate heat exchanger.

(The picture shows the VC GB 112 EH)

14.17 Releasing C.H. system pressure

Check C.H. service cocks are closed (3, Fig. 36).

Release pressure from the appliance by fitting a tube to drain nipple (B, Fig. 36) and unscrewing one turn.

Drain water into suitable container.

14.18 Draining boiler C.H. circuit

Release C.H. system pressure (14.17).

Drain the boiler by opening air vent (1, Fig. 68) and draining C.H. side of appliance through both drain nipples.

Drain water into a suitable container.

(The picture shows the VC GB 112 EH)

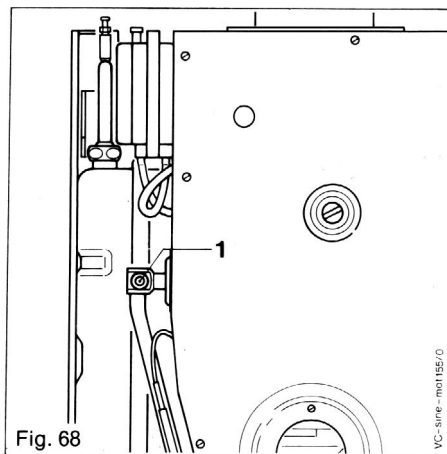

Fig. 68

15 Fault Finding

Before proceeding, check the following:

- 1) Carry out preliminary electrical safety checks (see 11.1).
- 2) Turn ON external electrical supply and check external controls are calling for heat.
- 3) Turn ON gas supply and appliance gas service cock.
- 4) Check gas supply pressure at appliance.
- 5) Set boiler main switch to position 1 (ON).
- 6) Check lock out reset button is reset (push in black button on control box).

Always start fault finding procedure with sheet A and follow complete sequence through to sheet F.

Finally complete with electrical safety checks (see 11.1.).

Sheet A Check electrical supply

Ensure main switch ON (Position 1)

Does red neon glow in main switch? → Y Go to B

↓ N

Ext. Fault. ← N Is 230-240 V~ present at input terminals 1 and 2 (N-L)?

↓ Y

Check/replace 2 A fuses (Spares provided with boiler)
If fuses intact, replace Main Switch Circuit Board.
If fuse(s) blown, suspect external control fault. (See Note 1)

Note 1

Disconnect external control wiring from terminal 3 and 4 and replace with a bridge between these terminals. If boiler then operates, fault is with external controls.

Sheet B Check main switch and overheat cut-off device

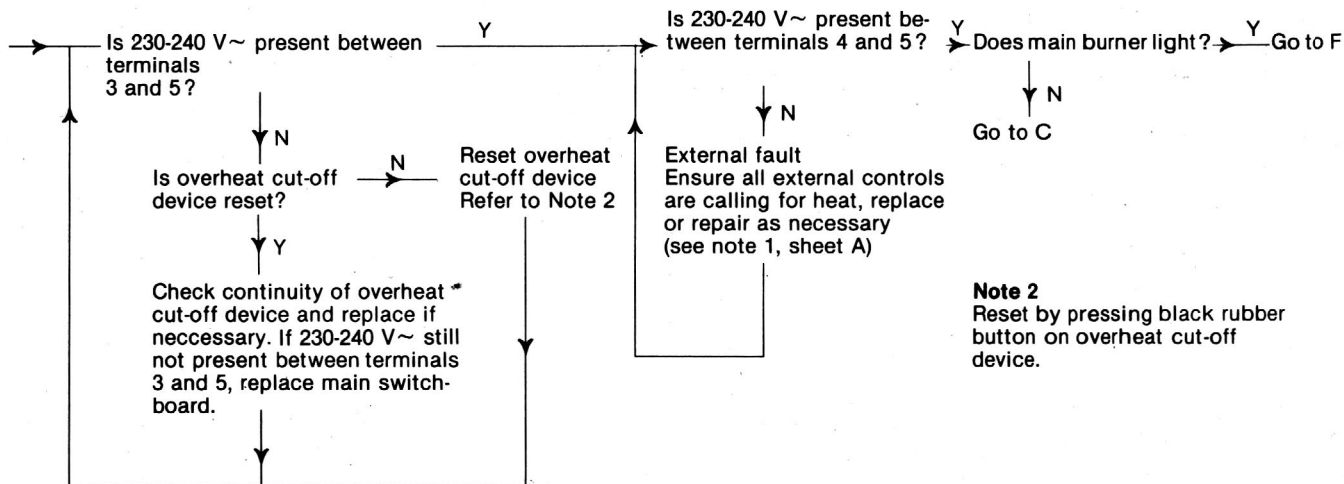

Note 2

Reset by pressing black rubber button on overheat cut-off device.

Sheet C Check operation of pump

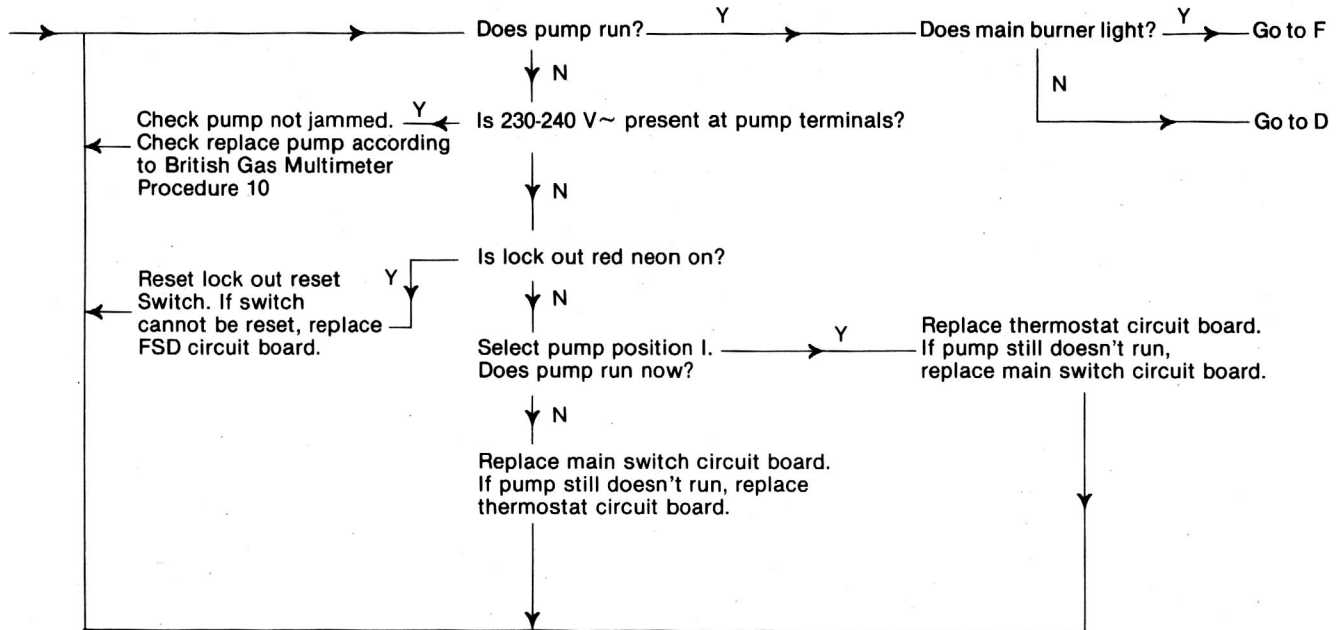

Sheet D Check Flue fan system

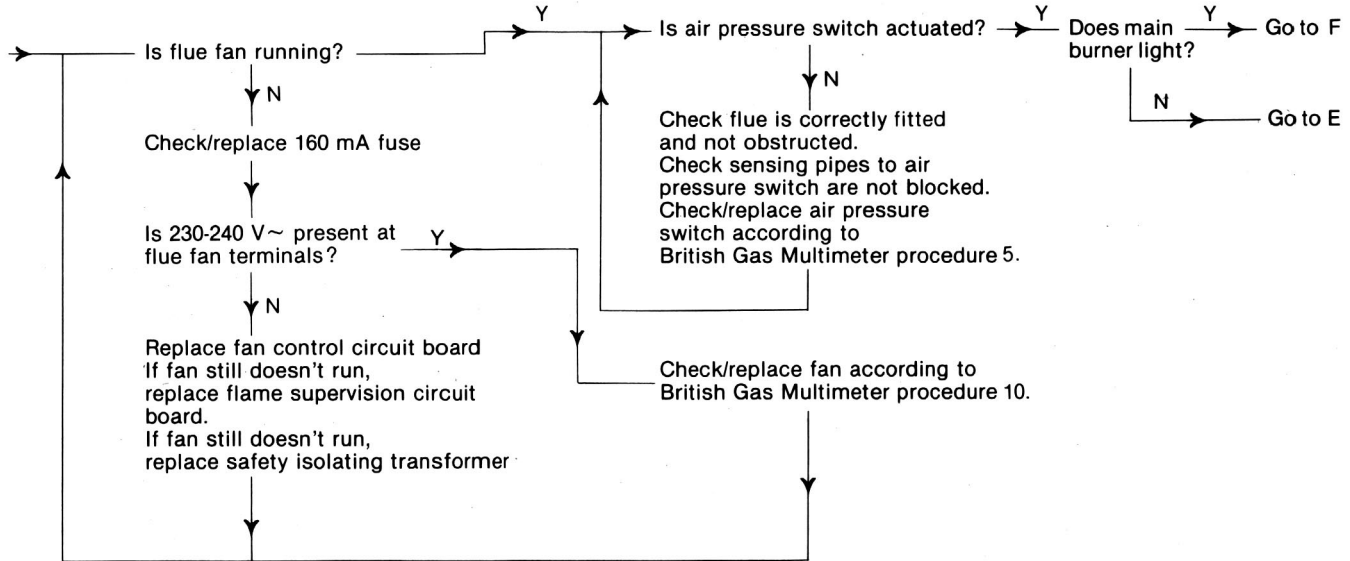

Sheet E Check Ignition system and gas section

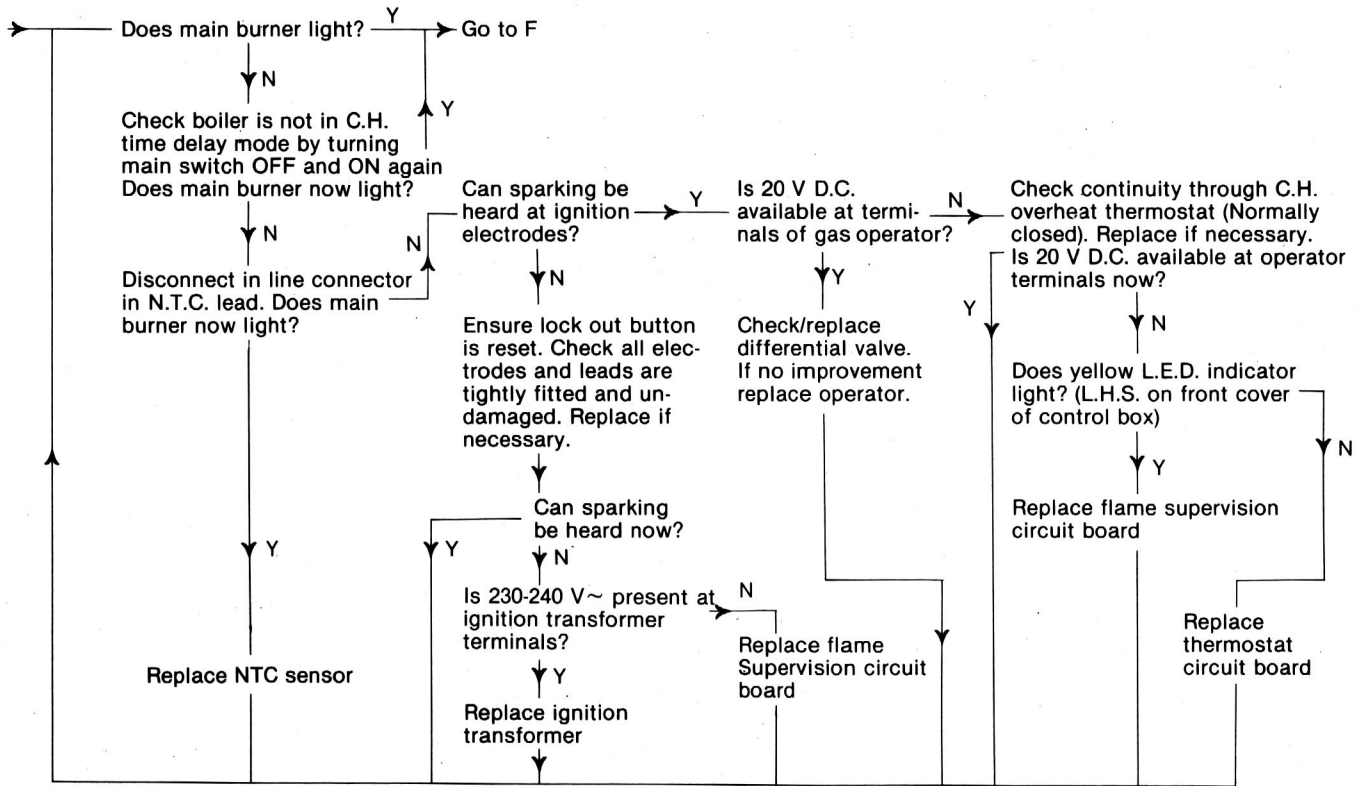

Sheet F Check burner modulation

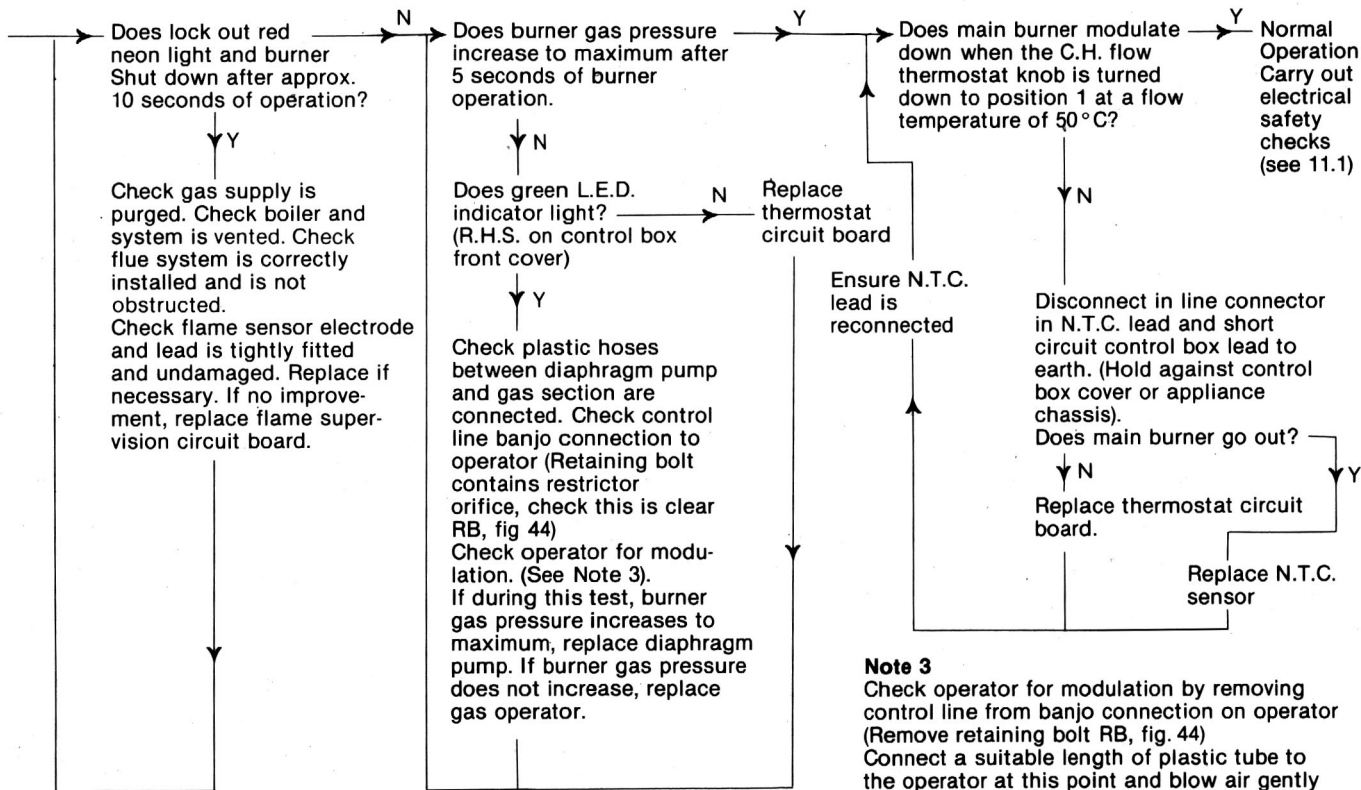

Note 3
 Check operator for modulation by removing control line from banjo connection on operator (Remove retaining bolt RB, fig. 44) Connect a suitable length of plastic tube to the operator at this point and blow air gently into operator using mouth pressure only.

16 Electrical Diagrams

16.1 Functional Flow Diagram

Note: This diagram applies to boilers with "HY" marked on electronic control box front cover.

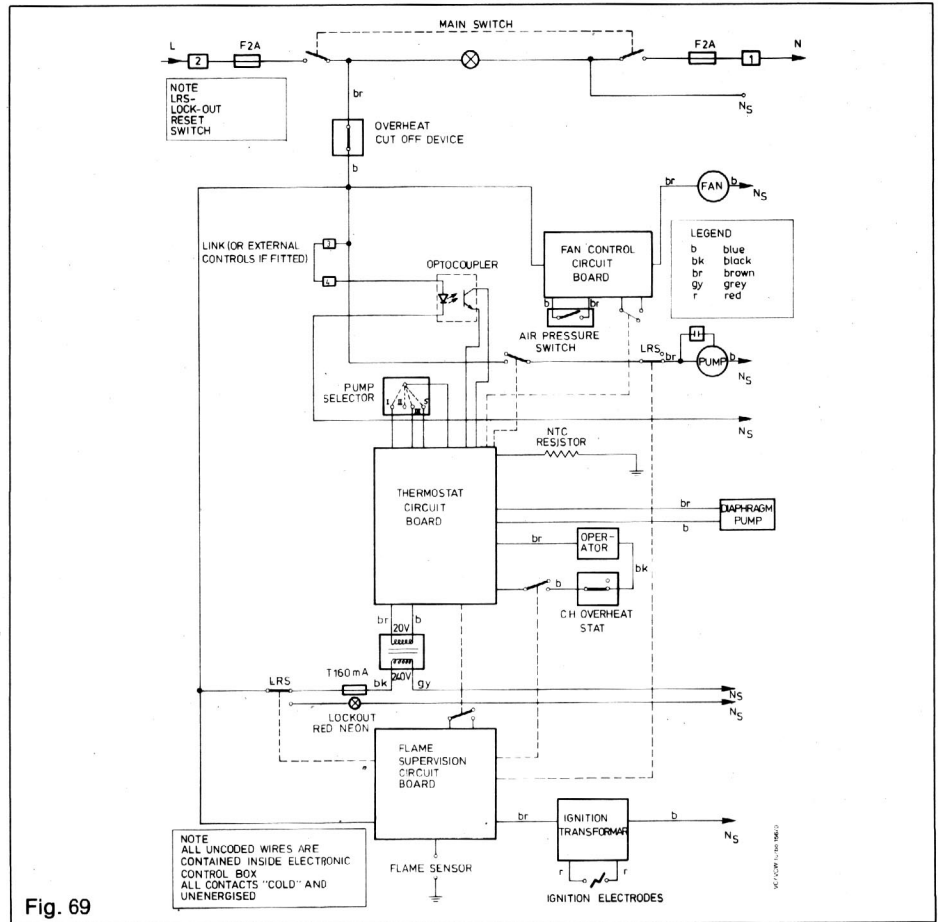

16.2 Wiring Diagram

Wiring diagram for VC GB 112 EH

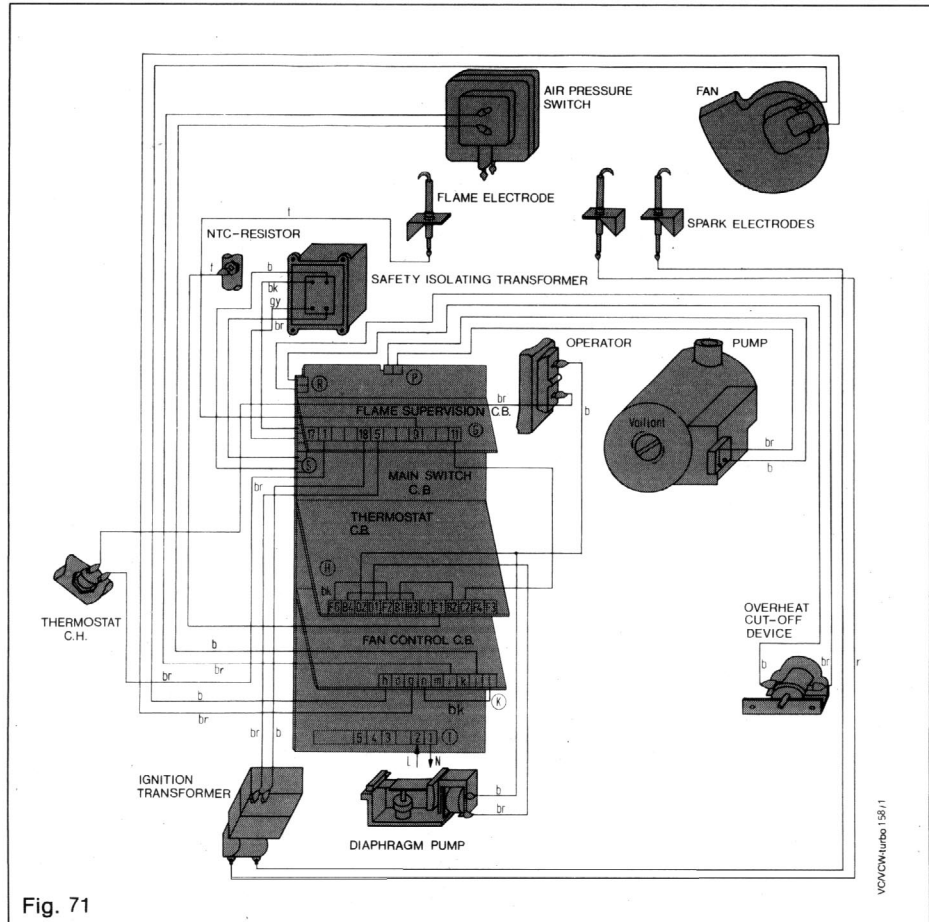

Fig. 71

Legend

- br = brown
- b = blue
- bk = black
- r = red
- t = transparent

17 Short part list

Key No.	Description	Part No.	G.C. No.
76	burner chamber group	04-0467	255211
77	monitoring electrode right cpl.	09-0649	255213
79	ignition electrodes	09-0665	255215
89	high tension lead	09-1513	255222
120	primary heat exchanger cpl.	06-1849	264162
132	cowling	07-2914	264167
133	screen plate cpl.	07-5460	264168
169	air pressure switch	05-0518	255273
191	circulating pump	16-1079	264177
192	automatic air vent	06-1707	263935
193	packing ring	98-0287	262316
202	expansion vessel	18-1005	264184
264	ignition transformer	09-1222	255330
261	thermometer	10-1542	255327
262	pressure gauge	10-1250	255328
269	flame supervision device	10-0522	255335
270	burner chamber group (VC GB 142 EH)	04-1920	264219
271	ignition electrode left cpl. (VC GB 142 EH)	09-0673	255215

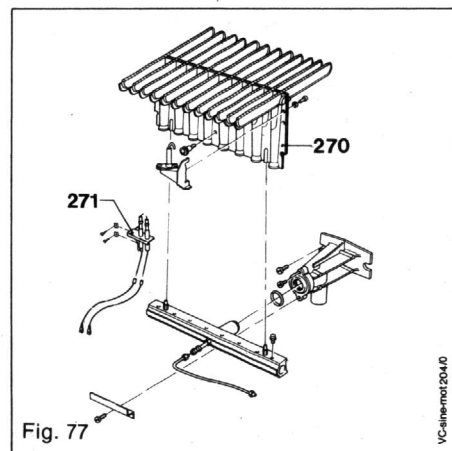
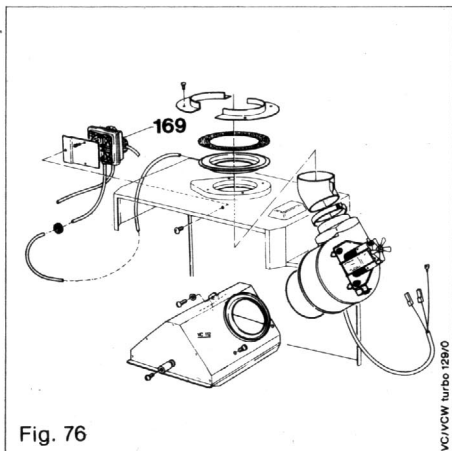
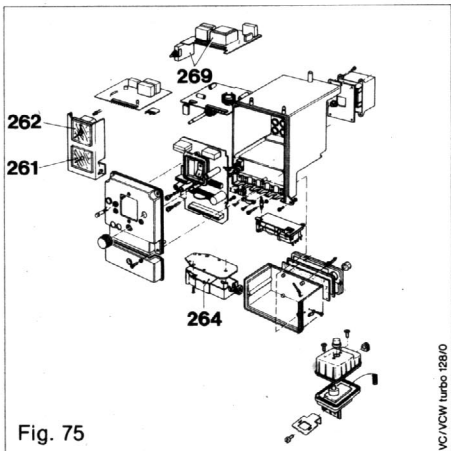
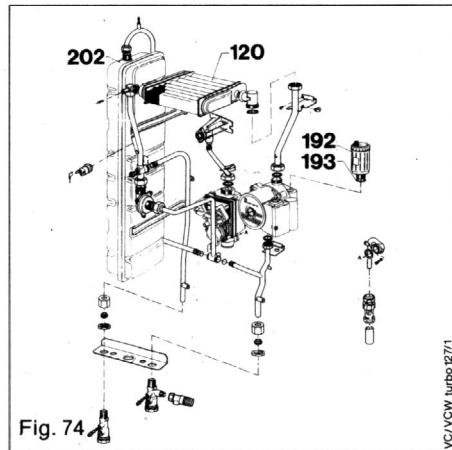
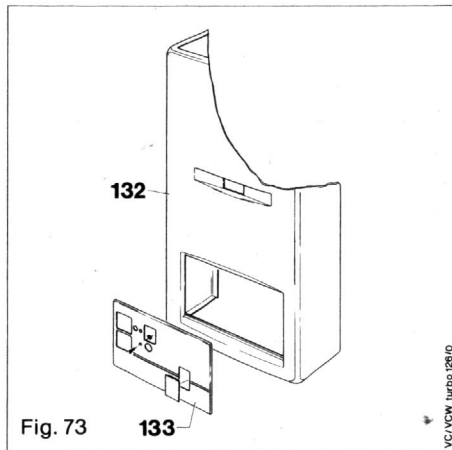
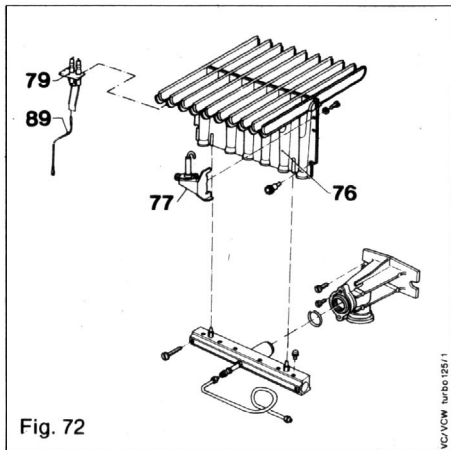

SUPPLEMENT TO INSTRUCTIONS FOR INSTALLATION 83 12 79

The appliance delivered is designed for use with LPG.
Please read the instructions for installation therefore as follows:

Related documents to be supplemented by:
BS 5482: CP for domestic butane- and propane-gas-burning installations
Part 1: Installations in permanent dwellings

Inlet pressure: Propane
37 mbar (14.9 in W.G.)

Technical Data

Type	VCGB 112E B	VCGB 142E B	
Main burner jet size	6 x 7/78	8 x 7/78	number x mark.
Burner setting pressure	26.0 ± 2.6 (10.4) Propane	33.2 ± 3.3 (13.3) Propane	mbar (in W.G.)
Restrictor	305	2 325	marking
Delivered gas			
Propane	G 31	G 31	
Gross C.V. (s.t.p.)	101.8 (2730)	101.8 (2730)	MJ/m ³ (Btu/ft ³)
Gas consumption (s.r.c.)	0.49 (0.29)	0.66 (0.39)	m ³ /h (c.f.m.)

SUPPLEMENT TO INSTRUCTIONS FOR INSTALLATION 83 12 79

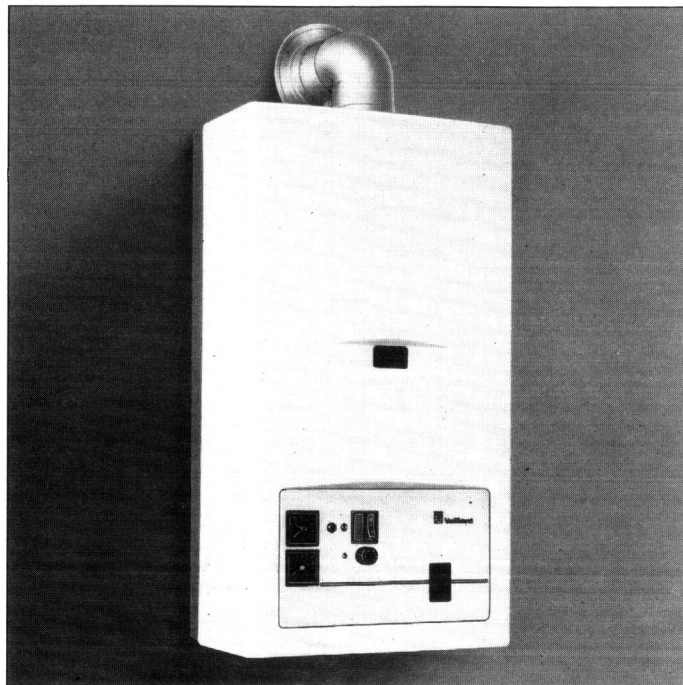

Fan-assisted
Room Sealed type

THERMOcompact®
boiler

VC GB 112 E B

VC GB 142 E B



Vaillant

HEATING, CONTROLS, HOT WATER.

18 Technical data

¹⁾ For systems having a larger water capacity an additional expansion vessel can be installed easily.

We cannot accept responsibility for damage caused as a result of non-observance of these installation and servicing instructions.
Subject to alteration.



Head Office Vaillant Ltd.,

Vaillant House,
Medway City Estate, Trident Close,
Rochester, Kent ME 2 4EZ

Sales 01634-292310
Technical 01634-292392
Service Freephone 0800-318076
Training 01634-292370

1 095 V
Printed in Germany - Imprimé en Allemagne
Printed on 100% recycled paper

Type	VC GB 112 EH	VC GB 142 EH	Units	
Nominal heating capacity	10.5 (35 840) (37.8)	14.0 (47 780) (50.4)	kW (BTU/h) (MJ/h)	
Nominal heating input (based on gross C.V.)	13.0 (44 370) (46.8)	17.8 (60 750) (64.1)	kW (BTU/h) (MJ/h)	
Main burner jet size for NG	6 x 7/140	8 x 7/140	number x mark.	
Burner setting pressure	max. rate	8.2±0.8 (3.3±0.3)	8.0±0.8 (3.2±0.3)	mbar (in WG)
	ignition rate	1.9 (0.8)	1.5 (0.6)	mbar (in WG)
Minimum water flow for heating system 20 °C rise	452 (99)	602 (132)	l/h (Imp. Gal./h)	
Delivered gas Gross C.V. (s.t.) Gas consumption (s.t.)	G 20 37.8 (1014) 1.24 (0.73)	G 20 37.8 (1014) 1.70 (1.00)	MJ/m ³ (BTU/ft ³) m ³ /h (ft ³ /min.)	
	Water capacity of heat exchanger	0.41 (0.09)	0.41 (0.09)	l (Imp. Gal.)
	Max. nominal flow temperature	90 (194)	90 (194)	°C (°F)
Maximum total water capacity of heating system (cold ¹⁾) for sealed system	90 (20)	90 (20)	l (Imp. Gal.)	
Pump pressure available for central heating system appliance as delivered	0.25 (8.4)	0.25 (8.4)	bar (feet)	
Weight	40 (88)	40 (88)	kg (pound)	
Electric connection	230-240/50 95 2 / 3	230-240/50 95 2 / 3	V~/Hz W Amp (slow)	